

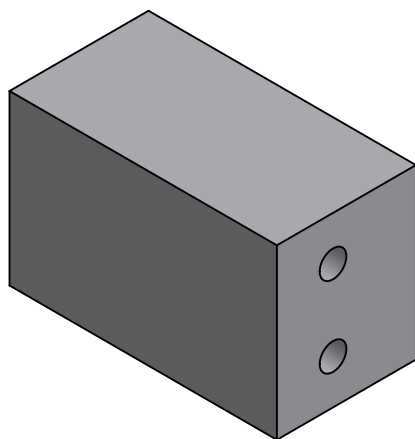

1.6/

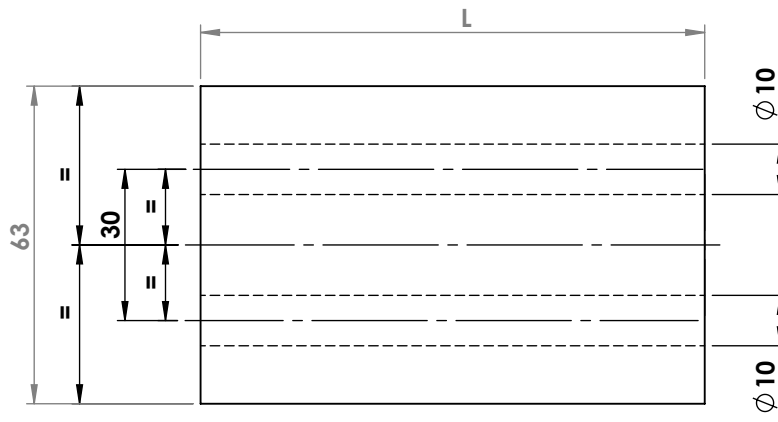
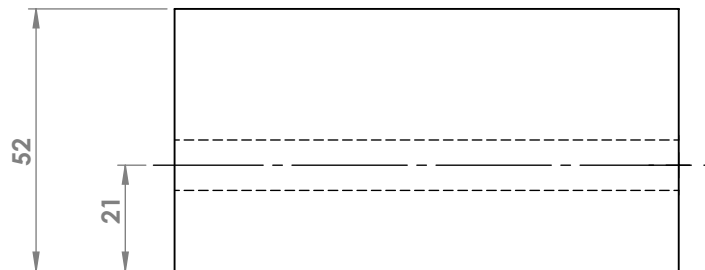

**Note:**

- **DEBURR ALL SHARP EDGES**
- **CHAMFER ALL DRILLS AND BORES 0.5x45° WHILE MACHINING**

Permissible deviation in mm for ranges in nominal lengths	
Over 0.5 upto 6	±0.1
Over 6 upto 30	±0.2
Over 30 upto 120	±0.3
Over 120 upto 400	±0.5
Over 400 upto 1000	±0.8
Over 1000 upto 2000	±1.2
Over 2000 upto 4000	±2.0

 <b>SPEEDWAY MACHINES PRIVATE LIMITED</b>				PART NAME: <b>CHILLER EXTRUSION</b>	
UNLESS OTHERWISE SPECIFIED: DIMENSIONS ARE IN MILLIMETERS					
	NAME	SIGNATURE	DATE	MATERIAL: ALUMINIUM GRADE 6063	WEIGHT: 1235.09 gram
DRAWN	<b>RAVINDRA</b>		21-12-2022		A4
CHK'D	<b>T.SINGH</b>				
APPV'D	<b>P.SINGH</b>				
				SCALE: <b>N.T.S</b>	PART NO: <b>110799</b>