

BEFORE APPROVAL CHECK ALL DIMENSIONS PROPERLY

PROPOSED DRAWING

Q00364

NOTE:-

R= 1.50R

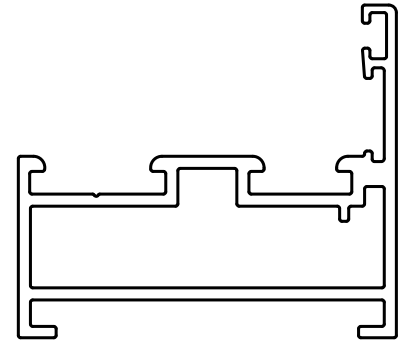

SCALE 1:1

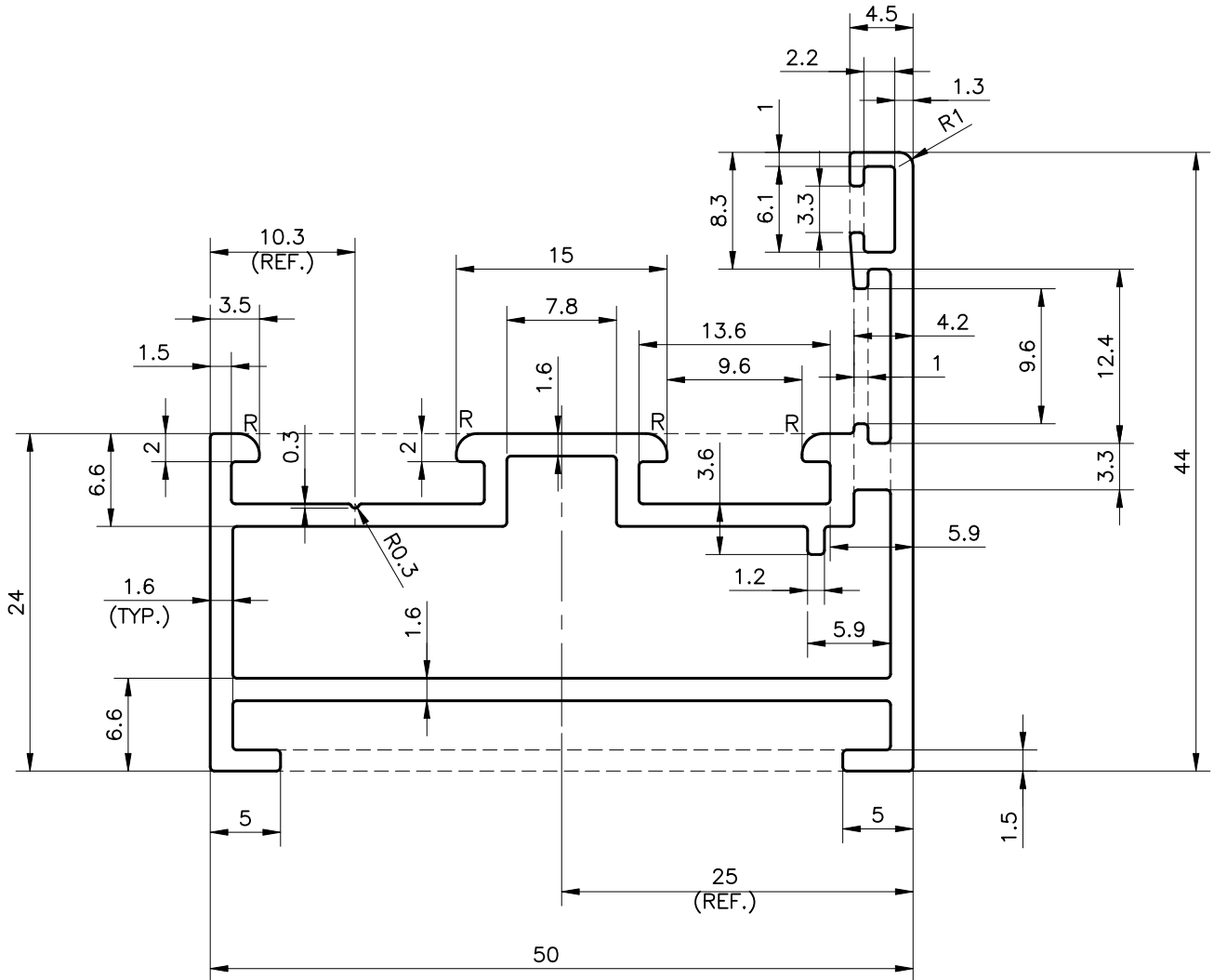

SYMBOL OF QUALITY
AN ISO 9001 COMPANY

JINDAL ALUMINIUM LTD.

BHIWADI-301019 (INDIA)

	NAME	DATE
DRAWN	ASHUTOSH	02-02-2023
CHECKED		
APPROVED		

1. ALL DIMENSIONS ARE IN mm.
2. ROUND OFF ALL SHARP CORNERS WITH 0.40 mm.
3. TOLERANCES WILL BE AS PER BS:EN-755-9 , UNLESS OTHERWISE SPECIFIED

SCALE	1:1&2:1
AREA mm ²	323.50
PERIMETER mm.	262.55
WEIGHT kg/m	0.874
DRAWING No.	SECTION No.
-	

PARTY'S NAME	M/s. PRANAV DOORS & WINDOWS
PARTY'S DRAWING No.	AS PER DRAWING -PF0083 (Q00364)
ALLOY & TEMPER	6063-T6
DESCRIPTION	MISC. SECTION