

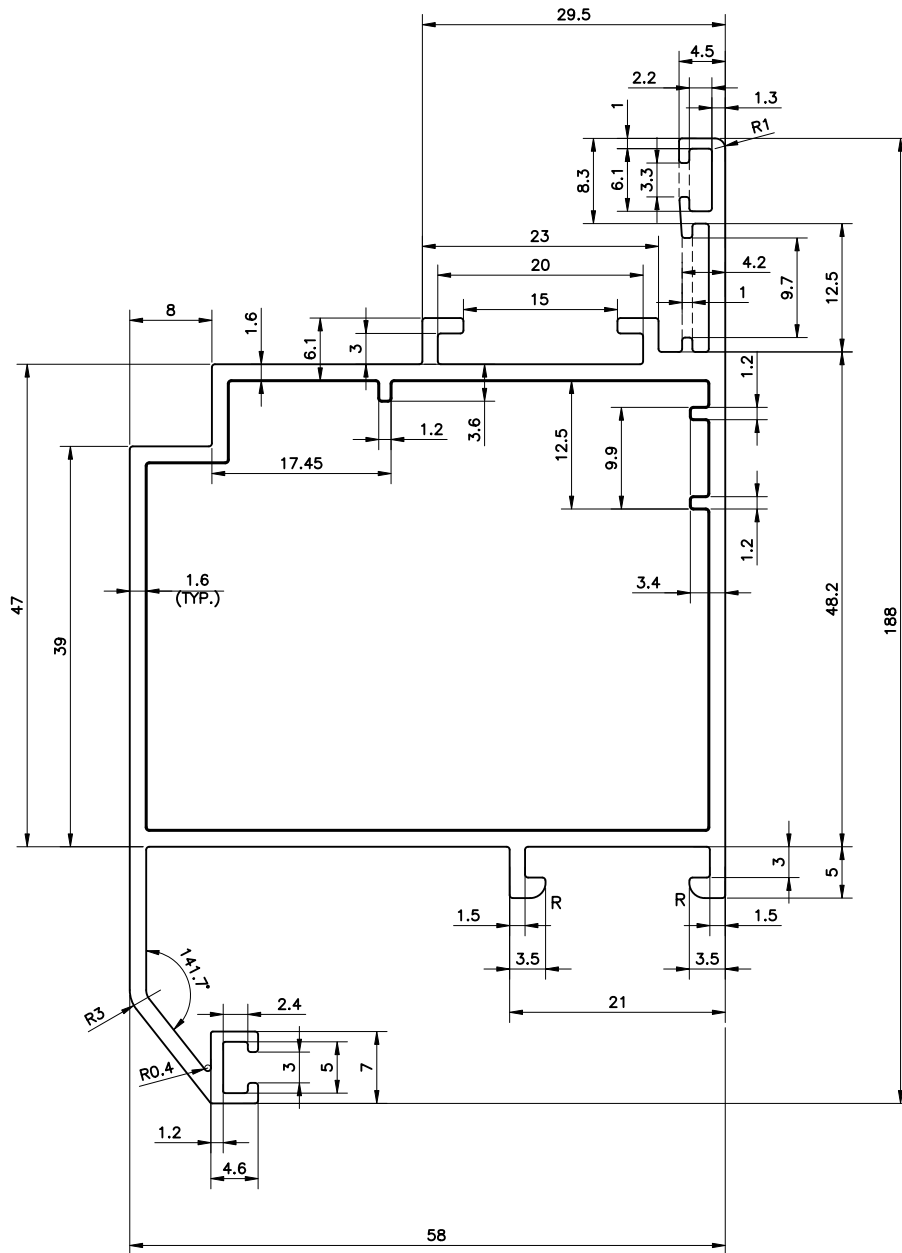

BEFORE APPROVAL CHECK ALL DIMENSIONS PROPERLY

PROPOSED DRAWING

Q00369

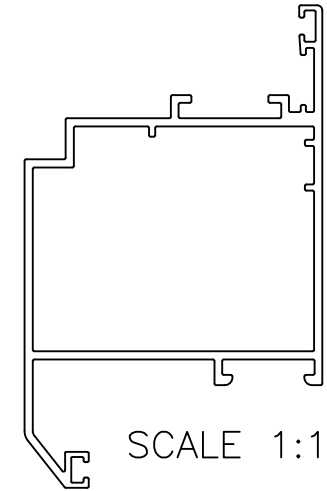

NOTE:-  
R= 1.50R

 SYMBOL OF QUALITY AN ISO 9001 COMPANY	<b>JINDAL ALUMINIUM LTD.</b> BHIWADI-301019 (INDIA)		NAME	DATE
			DRAWN	ASHUTOSH
1. ALL DIMENSIONS ARE IN mm. 2. ROUND OFF ALL SHARP CORNERS WITH 0.40 mm. 3. TOLERANCES WILL BE AS PER BS:EN-755-9 , UNLESS OTHERWISE SPECIFIED			CHECKED	
			APPROVED	
PARTY'S NAME M/S. PRANAV DOORS & WINDOWS			SCALE	1:1&2:1
			AREA mm <sup>2</sup>	485.50
PARTY'S DRAWING No. AS PER DRAWING-PF0061 (Q00369)			PERIMETER mm.	403.18
			WEIGHT kg/m	1.311
ALLOY & TEMPER 6063-T6			DRAWING No.	SECTION No.
DESCRIPTION -				