

BEFORE APPROVAL CHECK ALL DIMENSIONS PROPERLY

PROPOSED DRAWING

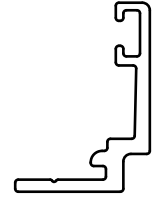

Q00379

SCALE 1:1

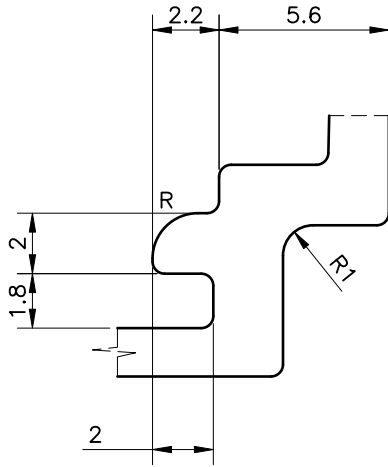

DETAIL A
SCALE 4:1

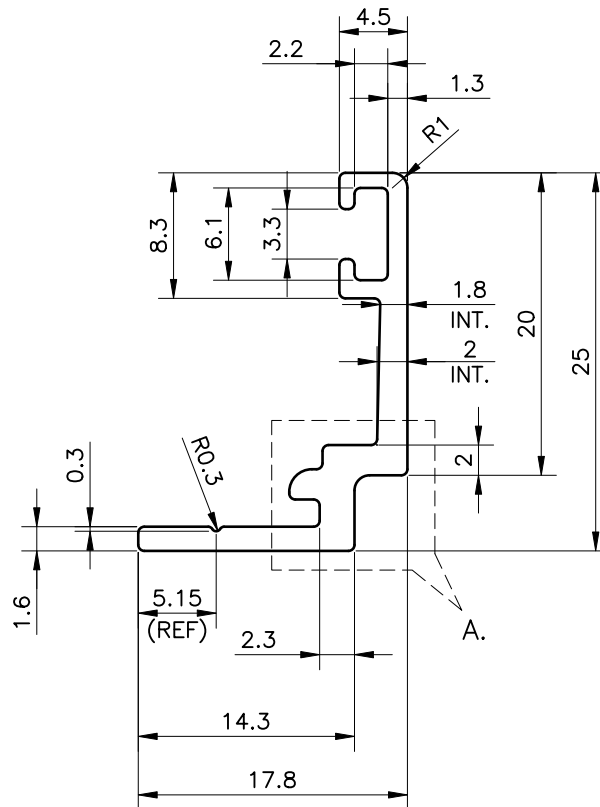

NOTE:-

R = 1.50R



SYMBOL OF QUALITY
AN ISO 9001 COMPANY

JINDAL ALUMINIUM LTD.
BHIWADI-301019 (INDIA)

	NAME	DATE
DRAWN	AMIT	03-02-2023
CHECKED		
APPROVED		

1. ALL DIMENSIONS ARE IN mm.
2. ROUND OFF ALL SHARP CORNERS WITH 0.40 mm.
3. TOLERANCES WILL BE AS PER BS:EN-755-9 , UNLESS OTHERWISE SPECIFIED

SCALE	1:1,2:1&4:1
AREA mm ²	84.36
PERIMETER mm.	101.942
WEIGHT kg/m	0.228

PARTY'S NAME	M/s. PRANAV DOORS & WINDOWS
PARTY'S DRAWING No.	AS PER DRAWING - PF0098 (Q00379)
ALLOY & TEMPER	6063-T6
DESCRIPTION	--

DRAWING No.	SECTION No.
-	-
-	-
-	-