

BILL OF MATERIAL							
ITEM	QTY	PART NAME	PART NUMBER	MATERIAL SPEC.	MASS (Kg)	CSA (in ²)	TSA (in ²)
1	--	OUTER	I-ST18202-D12	ALUMINIUM 6082-T6 ASTM B221-05A or ALUMINIUM 6061-T6 ASTM B221-05A	0.036kg	7.889in ²	17.529in ²

VERSION	PLACES	DESCRIPTION	CHANGED BY	DATE	APD. BY
A	---	INITIAL RELEASE	-----	30.08.2022	S.A.
B	---	RELEASE FOR DEVELOPMENT	MANISH	07.11.2022	S.A.
C	1	C1 WAS 29±0.25	MANISH	10.12.2022	S.A.
D	1	WAS 29.5±0.15	MANISH	23.01.2023	S.A.

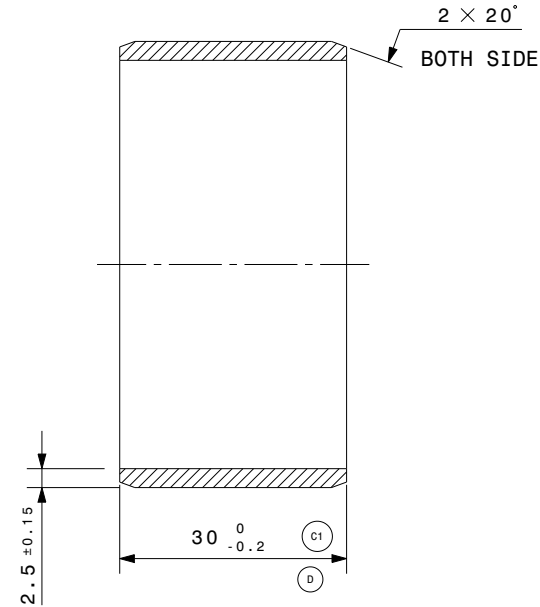
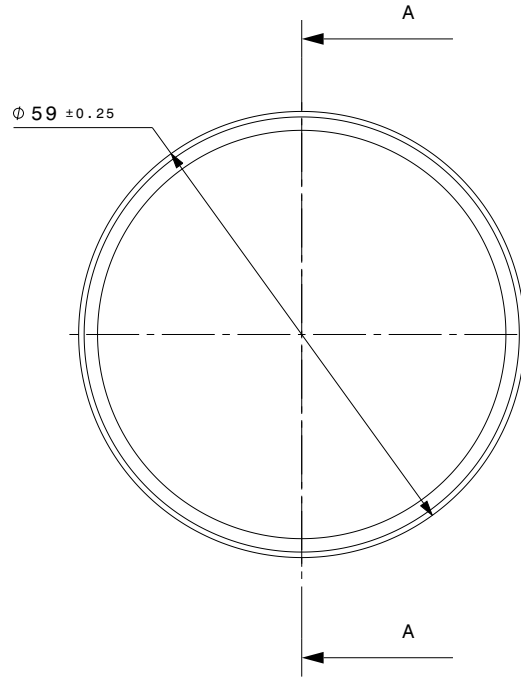

Section view A-A

FOR DEVELOPMENT ONLY
 Issue Date : 23/01/23
 Issued By : MANISH

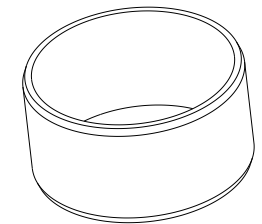

Isometric view

NOTES

- * FOR UNSPECIFIED DIMENSION REFER 3D CAD DATA.
- * REMOVE ALL SHARP EDGES AND BURRS.

<input type="checkbox"/> FOR QUOTATION	DRAWN BY	MANISH KUMAR		PART NAME	OUTER	 ANAND NVH PRODUCTS (P) LTD <small>N.H.-8 SECTOR 35 GURGAON HARYANA-122001 (INDIA) PROPERTY OF ANP</small>
<input type="checkbox"/> FOR COSTING	CHECKED BY	PANKAJ KASAR		PART NUMBER	I-ST18202-D12	
<input checked="" type="checkbox"/> FOR DEVELOPMENT	APPROVED BY	S.ADHIMOOMAM		TOLERANCED: ISO 2768-mk ISO 8015 (ASC) : ANAND SPECIAL CHARACTERISTIC		
<input type="checkbox"/> FOR SERIAL PRODUCTION	CAD SYSTEM: CATIA V5	PROTECTION MARK: ISO 16016	DATE: 30.08.2022	MODEL IS MASTER FOR ALL NON-DIMENSIONED FEATURES	REFERENCE PART NO	I-ST18202-D00