

BILL OF MATERIAL							
ITEM	QTY	PART NAME	PART NUMBER	MATERIAL SPEC.	MASS (Kg)	CA (in <sup>2</sup> )	TSA (in <sup>2</sup> )
1	---	INNER	I-ST18202-D11	ALUMINIUM 6082-T6 / 6061-T6 ASTM B221-05A	0.083kg	7.251in <sup>2</sup>	13.637in <sup>2</sup>

VERSION	PLACES	DESCRIPTION	CHANGED BY	DATE	APD. BY
A	---	INITIAL RELEASE	-----	30.08.2022	S.A.
B	---	RELEASE FOR DEVELOPMENT	MANISH	07.11.2022	S.A.
C	---	INNER PROFILE UPDATED	MANISH	17.11.2022	S.A.

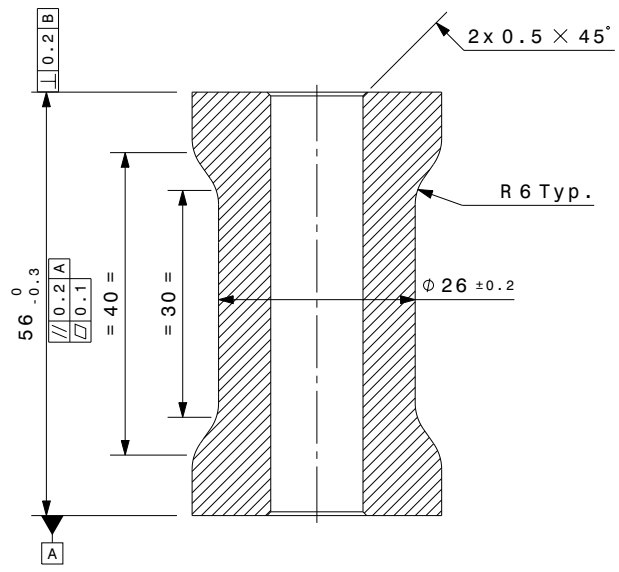
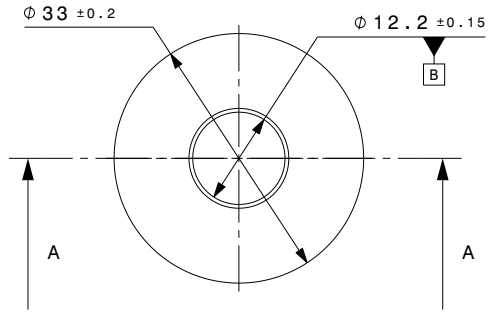

Section view A-A

**FOR DEVELOPMENT ONLY**  
 Issue Date : 18/11/22  
 Issued By : MANISH

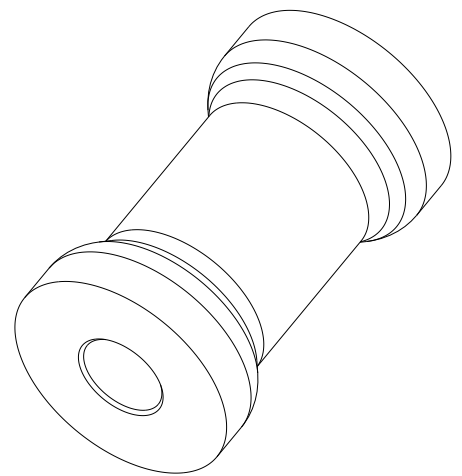

Isometric view  
 Scale: 1:1

**NOTES**

- \* BUCKLING LOAD 87 kN, CHANGE IN LENGTH  $\leq 0.2\%$  SLEEVE HEIGHT.
- \* REMOVE ALL SHARP EDGES AND BURRS.

<input type="checkbox"/> FOR QUOTATION	DRAWN BY: MANISH KUMAR	<i>[Signature]</i>	PART NAME: INNER	 <b>ANAND NVH PRODUCTS (P) LTD</b> N.H.-8 SECTOR 35 GURGAON HARYANA-122001 (INDIA) PROPERTY OF ANP
<input type="checkbox"/> FOR COSTING	CHECKED BY: PANKAJ KASAR	<i>[Signature]</i>	PART NUMBER: I-ST18202-D11	
<input checked="" type="checkbox"/> FOR DEVELOPMENT	APPROVED BY: S.ADHIMOOMAM	<i>[Signature]</i>		
<input type="checkbox"/> FOR SERIAL PRODUCTION	TOLERANCED: ISO 2768-mk ISO 8015		CAD SYSTEM: CATIA V5	PROTECTION MARK: ISO 16016
	FOR WEIGHT SEE BOM	DATE: 30.08.2022	(ASC) : ANAND SPECIAL CHARACTERISTIC	SHEET: 01
			MODEL IS MASTER FOR ALL NON-DIMENSIONED FEATURES	SCALE: NTS
			REFERENCE PART NO: I-ST18202-000	UNIT: mm