

BILL OF MATERIAL

ITEM	QTY	PART NAME	PART NUMBER	MATERIAL SPEC.	MASS (Kg)	CSA (in ²)	TSA (in ²)
1	--	OUTER	I-ST18201-D12	ALUMINIUM 6082-T6 / 6061-T6 ASTM B221-05A	0.029kg	7.768in ²	16.935in ²

VERSION	PLACES	DESCRIPTION	CHANGED BY	DATE	APD. BY
A	---	INITIAL RELEASE	-----	30.08.2022	S.A.
B	1	1. WAS 40.7±0.2	MANISH	30.09.2022	S.A.
C	---	RELEASE FOR DEVELOPMENT	MANISH	07.11.2022	S.A.

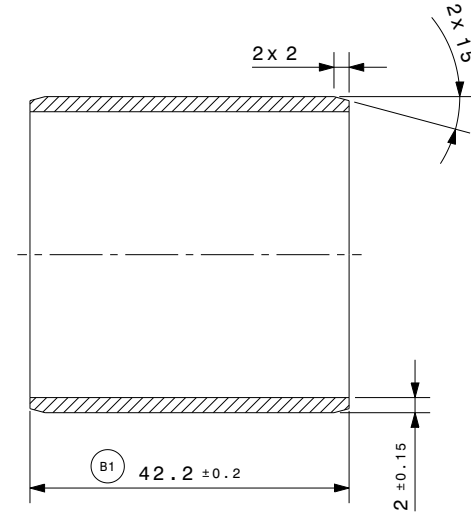
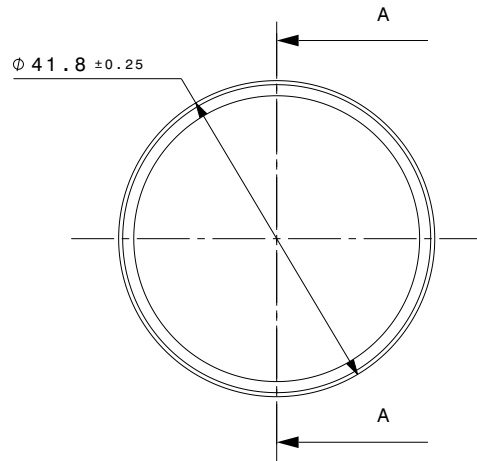

Section view A-A

**FOR DEVELOPMENT
ONLY**
Issue Date : 07/11/22
Issued By : MANISH

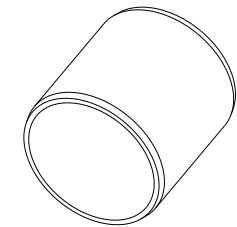

Isometric view

NOTES

- * FOR UNSPECIFIED DIMENSION REFER 3D CAD DATA.
- * REMOVE ALL SHARP EDGES AND BURRS.

<input type="checkbox"/> FOR QUOTATION	DRAWN BY	MANISH KUMAR		PART NAME	OUTER	 ANAND NVH PRODUCTS (P) LTD N.H.-8 SECTOR 35 GURGAON HARYANA-122001 (INDIA) PROPERTY OF ANP <small>THIS DRAWING IS SOLE PROPERTY OF ANP. IT SHOULD NOT BE COPIED BY ANYONE WITHOUT WRITTEN PERMISSION OF ANP.</small>
<input type="checkbox"/> FOR COSTING	CHECKED BY	PANKAJ KASAR		PART NUMBER	I-ST18201-D12	
<input checked="" type="checkbox"/> FOR DEVELOPMENT	APPROVED BY	S.ADHIMOOMAM		TOLERANCED: ISO 2768-mk ISO 8015 CAD SYSTEM: CATIA V5 PROTECTION MARK: ISO 16016 (ASC) : ANAND SPECIAL CHARACTERISTIC SHEET A1 SCALE NTS UNIT mm		
<input type="checkbox"/> FOR SERIAL PRODUCTION	FOR WEIGHT SEE BOM	DATE	30.08.2022	MODEL IS MASTER FOR ALL NON-DIMENSIONED FEATURES	REFERENCE PART NO	I-ST18201-000