

P--JAL--B--586

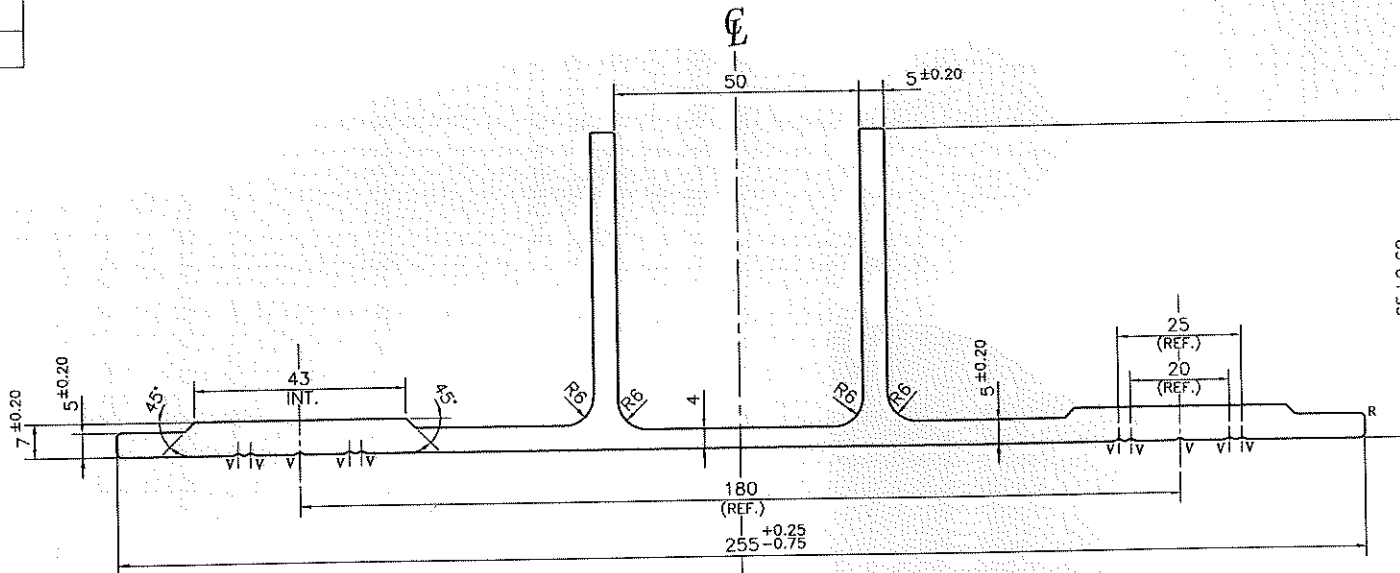

10 June 2024

NOTE:-

- ☞ ROUND OFF ALL SHARP CORNERS WITH 0.50 mm.
- ☞ FE:- NOT MORE THAN 0.4%, MG:- 0.8 TO 1.2%
- ☞ HARDNESS :- 56HRB
- ☞ UTS :- 280 TO 300 MIN MPA
- ☞ SOME DIMENSIONS AND REFERENCES ARE DIFFERENT IN CAD & PDF DRAWING PLEASE CHECK ALL DIMENSIONS AND PLEASE SPECIFY IF THIS PROFILE MATCHES WITH OTHER PROFILES.

255 x 65 x 5

201988

NOTE:-

- R= 1.0 RADIUS (4 PLACES)
- V= 0.5x120° V-GROOVE (10 PLACES)

- 1.Hardness:-56HRB
- 2.UTS:-280to300 min MPA
- 3.Flatness:-+/-0.45mm
- 4.Straightness:-1.00mm/mt
- 5.Twist:-1.00mm/mt
- 6.Angularity:-+/-1Deg.

- 1. STRAIGHTNESS= 1.0mm/M
- 2. TWIST= 1.0mm/M
- 3. ANGULARITY= ±1'
- 4. FLATNESS= ±0.45mm

UNCONTROLLED COPY

1) THE WELDING LINE IN THE EXPOSED SURFACE OF PROFILE IS UNAVOIDABLE. 2) PLEASE SPECIFY IMPORTANT SIZES
 3) PLEASE SPECIFY IF THIS PROFILE MATCHES WITH OTHER PROFILES. 4) PLEASE SPECIFY EXPOSED SURFACE. OTHER WISE CONSIDERED AS NO EXPOSED SURFACE. 5) FINISH :- MILL FINISH / ANODIZING / POWDER COATING

 SYMBOL OF QUALITY AN ISO 9001 COMPANY	JINDAL ALUMINIUM LTD. BHIWADI-301019 (INDIA)		NAME	DATE
	DRAWN	ASHUTOSH	05-06-2024	
	CHECKED			
APPROVED				
1. ALL DIMENSIONS ARE IN mm. 2. ROUND OFF ALL SHARP CORNERS WITH 0.50 mm. 3. TOLERANCES WILL BE AS PER EN 12020-2 , UNLESS OTHERWISE SPECIFIED			SCALE	1:1
			AREA mm ²	2029.417
			PERIMETER mm.	754.72
			WEIGHT kg/m	5.479
PARTY'S NAME	KNEST MANUFACTURERS LLP, PUNE		DRAWING No.	SECTION No.
PARTY'S DRAWING No.	AS PER DRAWING		P-JAL-B-586	--
ALLOY & TEMPER	6061 T6	PRODUCT CODE:-029		
		HSN CODE:- 76042990		
DESCRIPTION	FORM WORK SECTION- 155 TO 255 T PROFILE			