

BEFORE APPROVAL CHECK ALL DIMENSIONS PROPERLY

PROPOSED DRAWING

Q00394

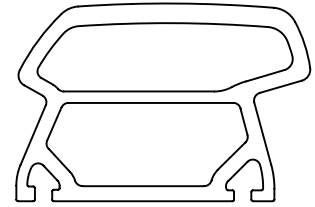

SCALE: -1:1

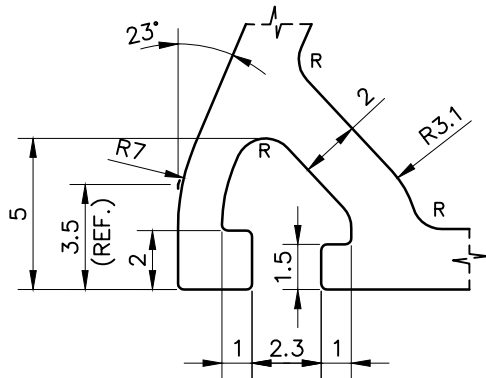

DETAIL A
SCALE 4:1

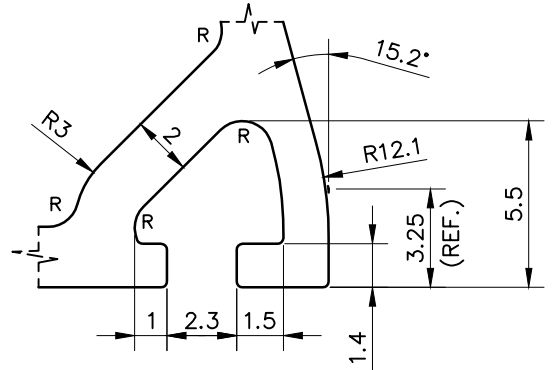

DETAIL B
SCALE 4:1

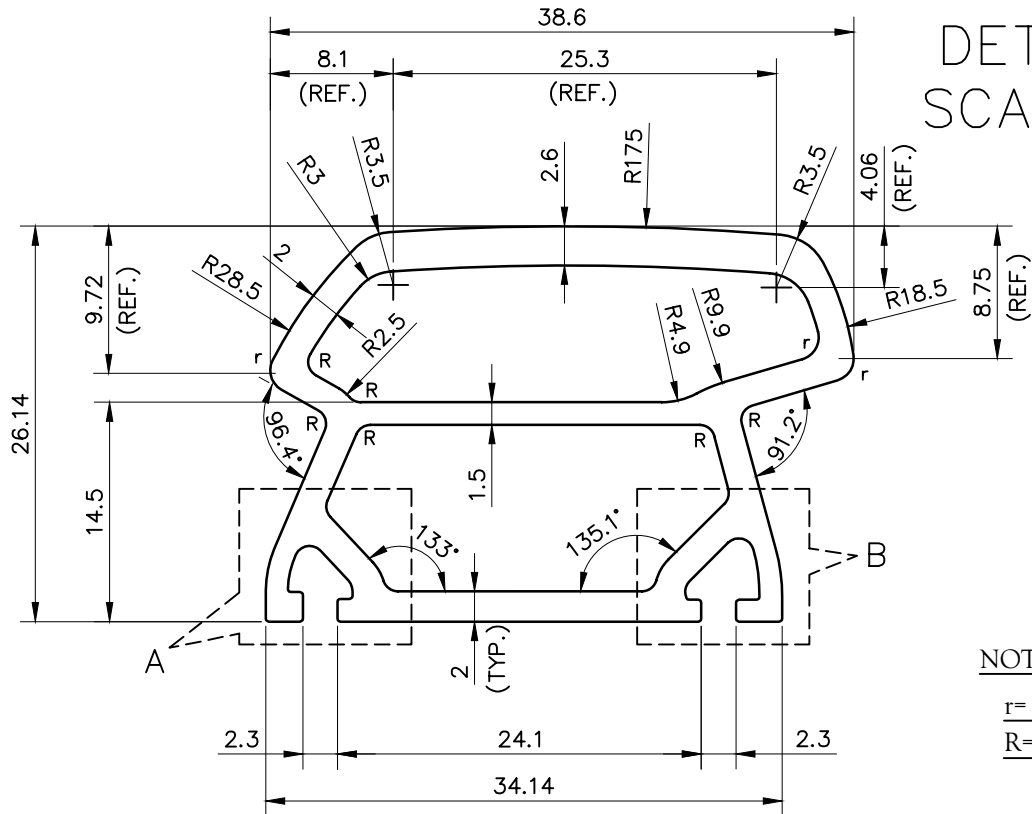

NOTE:-

$r = 1.50 R$
 $R = 1.00 R$



SYMBOL OF QUALITY
AN ISO 9001 COMPANY

JINDAL ALUMINIUM LTD.
BHIWADI-301019 (INDIA)

	NAME	DATE
DRAWN	AMIT	11-02-2023
CHECKED		
APPROVED		
SCALE	1:1,2:1&4:1	
AREA mm ²	301.44	
PERIMETER mm.	148.677	
WEIGHT kg/m	0.814	
DRAWING No.	SECTION No.	
-	-	
-	-	
-	-	

1. ALL DIMENSIONS ARE IN mm.
2. ROUND OFF ALL SHARP CORNERS WITH 0.40 mm.
3. TOLERANCES WILL BE AS PER BS:EN-755-9 , UNLESS OTHERWISE SPECIFIED

PARTY'S NAME	M/s. NTF (INDIA) PVT. LTD.
PARTY'S DRAWING No.	AS PER DRAWING-35 FAB 025 (Q00394)
ALLOY & TEMPER	6063-T6
DESCRIPTION	--