

BEFORE APPROVAL CHECK ALL DIMENSIONS PROPERLY

PROPOSED DRAWING

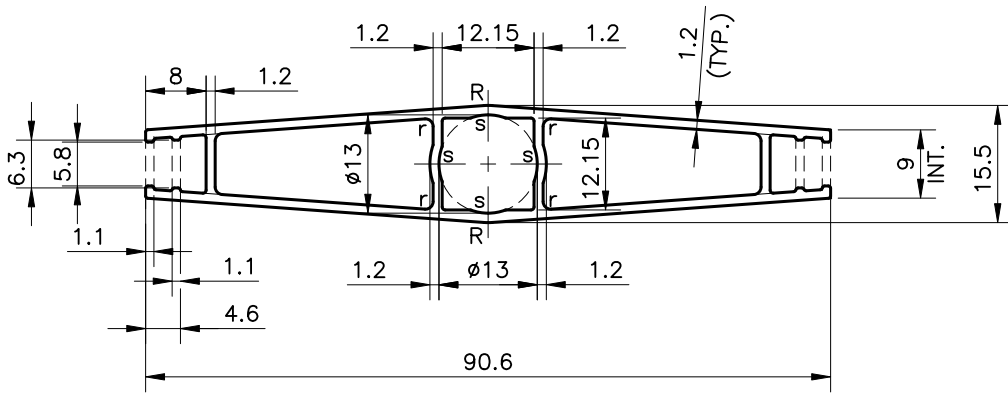

NOTE:-

$R = 7.75R$

$S = 6.50R$

$r = 1.00R$

 SYMBOL OF QUALITY AN ISO 9001 COMPANY	JINDAL ALUMINIUM LTD. BHIWADI-301019 (INDIA)	NAME		DATE	
		DRAWN	ASHUTOSH	11-02-2023	
		CHECKED			
1. ALL DIMENSIONS ARE IN mm. 2. ROUND OFF ALL SHARP CORNERS WITH 0.40 mm. 3. TOLERANCES WILL BE AS PER BS:EN-755-9 , UNLESS OTHERWISE SPECIFIED		SCALE		1:1	
PARTY'S NAME		M/s. SYSTEMAIR		AREA mm ²	276.04
		AS PER DRAWING -BLADE FRAME		PERIMETER mm.	236.62
ALLOY & TEMPER		6063-T6		WEIGHT kg/m	0.745
DESCRIPTION		-		DRAWING No.	SECTION No.
				-	