

BEFORE APPROVAL CHECK ALL DIMENSIONS PROPERLY

PROPOSED DRAWING

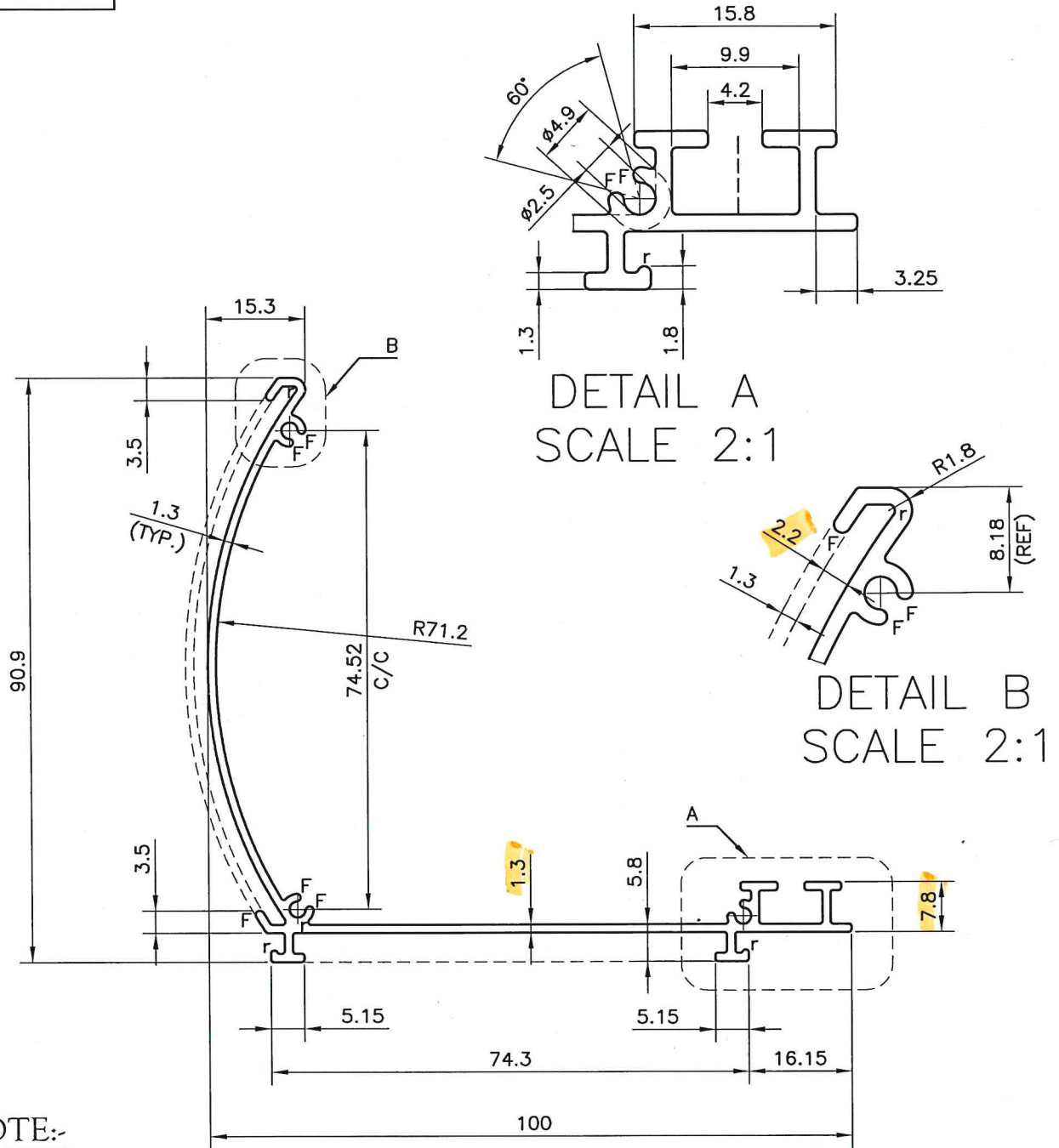

NOTE:-

$r = 0.50R$

F = FULL RADIUS



SYMBOL OF QUALITY
AN ISO 9001 COMPANY

JINDAL ALUMINIUM LTD.

BHIWADI-301019 (INDIA)

1. ALL DIMENSIONS ARE IN mm.
2. ROUND OFF ALL SHARP CORNERS WITH 0.40 mm.
3. TOLERANCES WILL BE AS PER BS:EN-755-9 , UNLESS OTHERWISE SPECIFIED

PARTY'S NAME M/s. JOHNSON

PARTY'S DRAWING No. AS PER SAMPLE

ALLOY & TEMPER 6063-T6

DESCRIPTION MISC. SECTION

	NAME	DATE
DRAWN	ASHUTOSH	09-02-2023
CHECKED		
APPROVED		
SCALE		1:1&2:1
AREA mm ²		318.22
PERIMETER mm.		476.06
WEIGHT kg/m		0.860
DRAWING No.		SECTION No.
-		