

BEFORE APPROVAL CHECK ALL DIMENSIONS PROPERLY

PROPOSED DRAWING

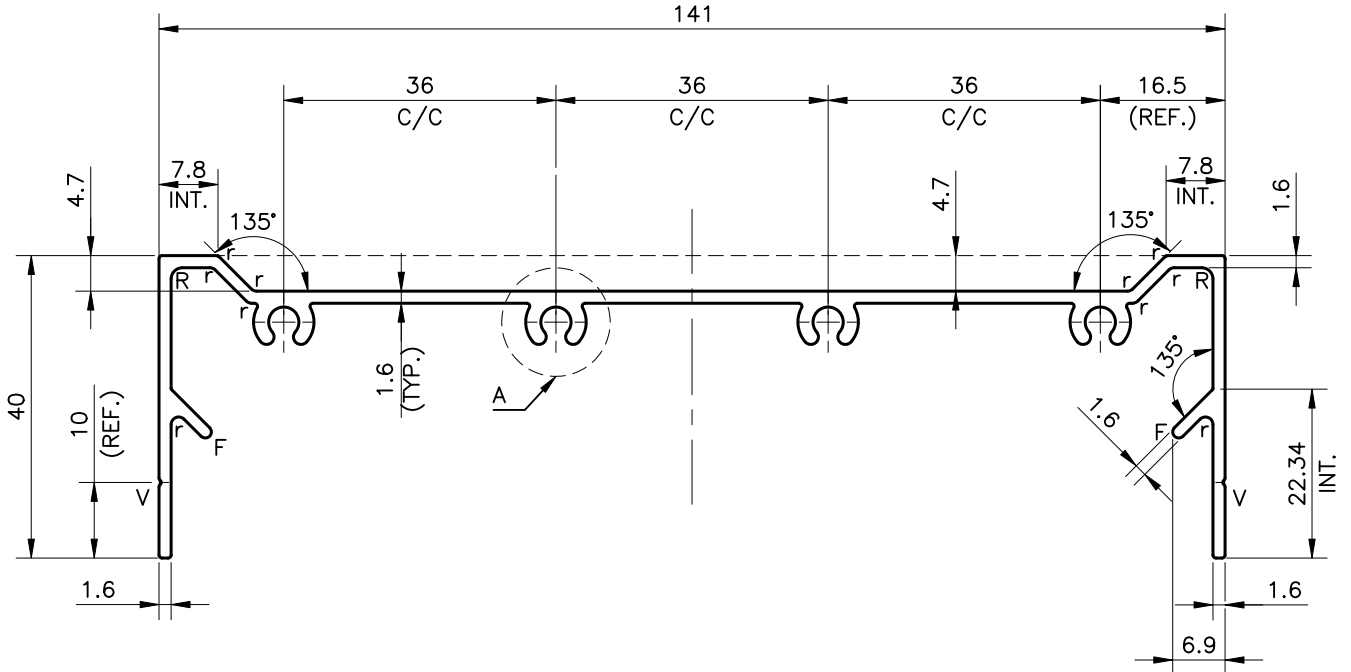

NOTE:-

$r = 1.00R$

$R = 1.50R$

$V = 0.30 \times 90^\circ$  V-GROOVE

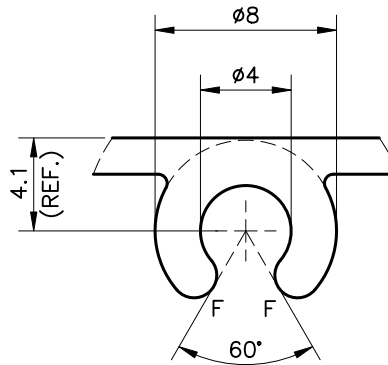

DETAIL A  
SCALE 3:1



SYMBOL OF QUALITY  
AN ISO 9001 COMPANY

**JINDAL ALUMINIUM LTD.**

BHIWADI-301019 (INDIA)

	NAME	DATE
DRAWN	ASHUTOSH	11-02-2023
CHECKED		
APPROVED		

1. ALL DIMENSIONS ARE IN mm.
2. ROUND OFF ALL SHARP CORNERS WITH 0.40 mm.
3. TOLERANCES WILL BE AS PER BS:EN-755-9 , UNLESS OTHERWISE SPECIFIED

SCALE	1:1&3:1
AREA mm <sup>2</sup>	476.89
PERIMETER mm.	541.24
WEIGHT kg/m	1.288

PARTY'S NAME	M/s. SYSTEMAIR	DRAWING No.	SECTION No.
PARTY'S DRAWING No.	AS PER DRAWING -SIDE FRAME	-	
ALLOY & TEMPER	6063-T6		
DESCRIPTION	-		