

EXTRUSION

BILL OF MATERIAL				
ITEM	DESCRIPTION	MATERIAL	PART NO	QTY.
01	AL EXTRUSION	6063T6	131266	01

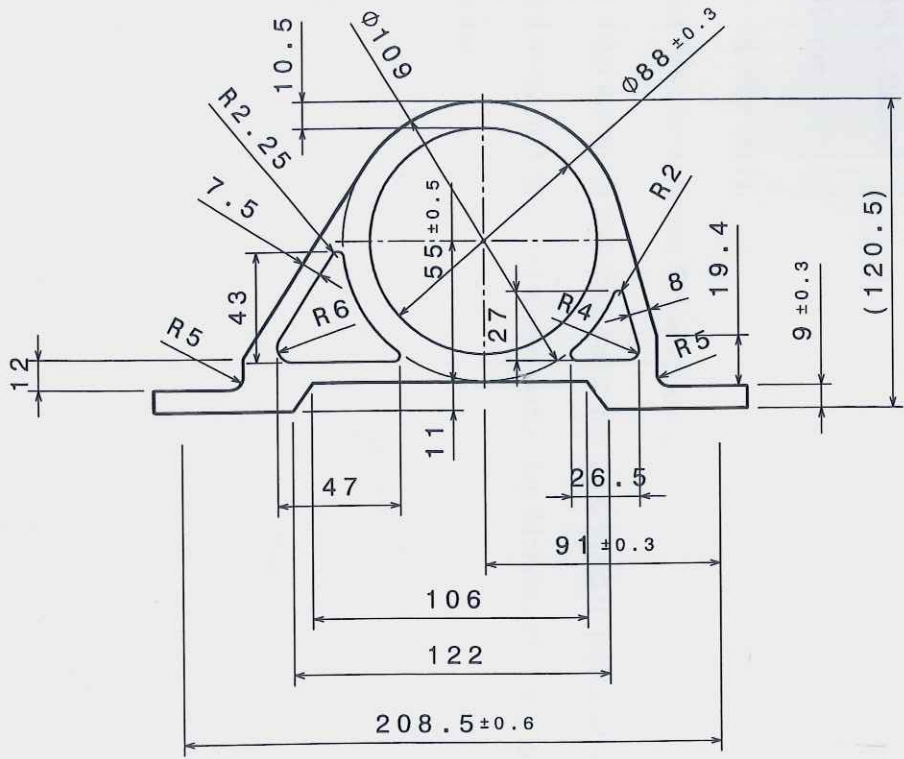

Q02018

REMOVE ALL SHARP EDGES & BURR							All dimensions in mm unless otherwise stated.				Special Characteristic Symbol	Safety Related	Key Fit & Function	Major
Dimensions	≤ 6	> 6 & ≤ 30	> 30 & ≤ 120	> 120 & ≤ 400	> 400 & ≤ 1000	> 1000	Do not scale drawing							
Metal	±0.1	±0.2	±0.3	±0.5	±0.8	±1.2					⊙	▲	0	
Rubber	±0.3	±0.5	±0.8	±1.2	±2	±3								
DRN	OPN	Stork Rubber Products Pvt Ltd					E							
	11.07.2023						D							
CHD	KULDEEP						C							
APD	BALBIR	B												
SIZE	A4	DESCRIPTION					A	11.07.2023	INITIAL REVISION					
		AL EXTRUSION												
SCALE	NTS	WEIGHT (gms)	PART NUMBER		FINAL CODE		REV NO.	DATE	REVISION DETAIL			ECN NO	DRN BY	APPD BY
		627	1301266		1006361									

The information contained in this document is property of Stork Rubber Product Pvt Ltd. It is not to be shared or reproduced without permission.