

BEFORE APPROVAL CHECK ALL DIMENSIONS PROPERLY

PROPOSED DRAWING

Q00432

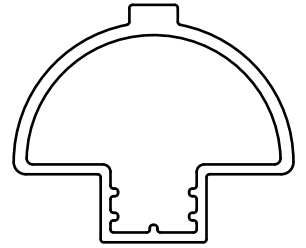

SCALE 1:1

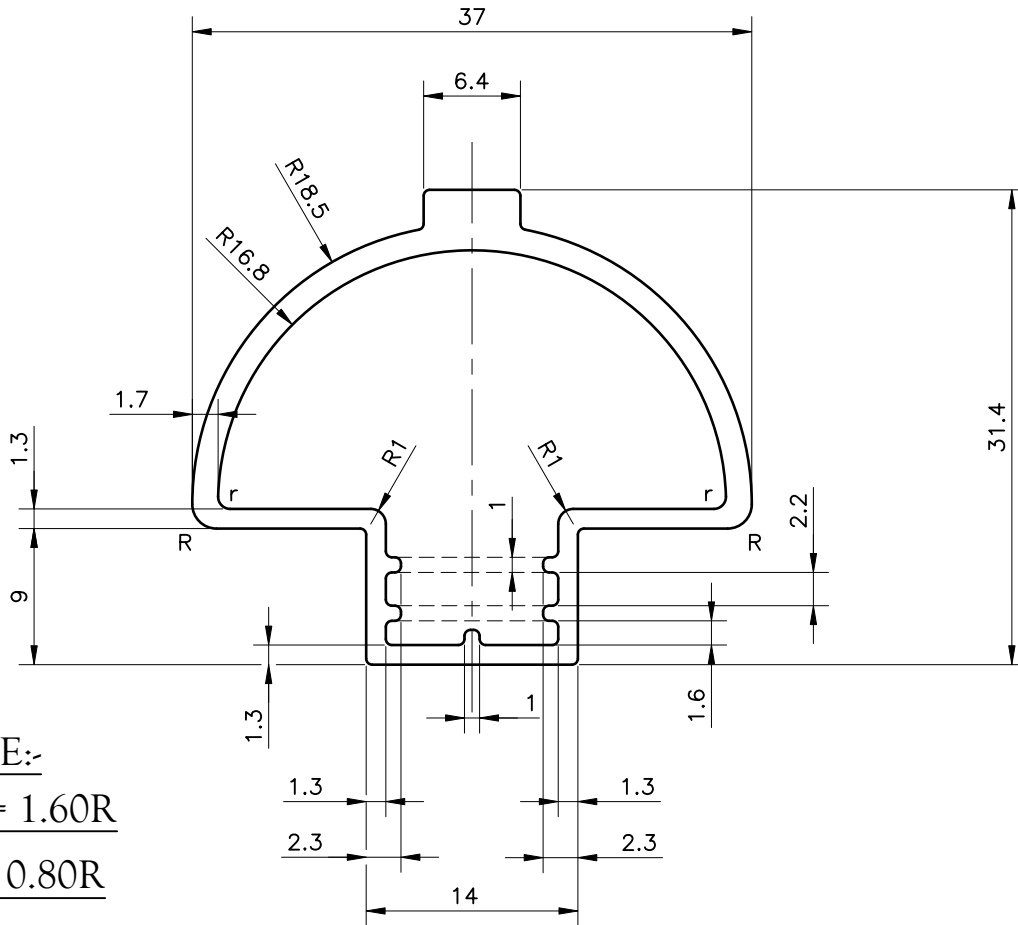

NOTE:-

$R = 1.60R$

$r = 0.80R$



SYMBOL OF QUALITY  
AN ISO 9001 COMPANY

**JINDAL ALUMINIUM LTD.**  
BHIWADI-301019 (INDIA)

	NAME	DATE
DRAWN	ASHUTOSH	09-03-2023
CHECKED		
APPROVED		

1. ALL DIMENSIONS ARE IN mm.
2. ROUND OFF ALL SHARP CORNERS WITH 0.40 mm.
3. TOLERANCES WILL BE AS PER BS:EN-755-9 , UNLESS OTHERWISE SPECIFIED

SCALE	1:1&2:1
AREA mm <sup>2</sup>	185.90
PERIMETER mm.	118.82
WEIGHT kg/m	0.502

PARTY'S NAME	M/s. INDICATION INSTRUMENTS LIMITED
PARTY'S DRAWING No.	AS PER DRAWING -Q00432
ALLOY & TEMPER	6063-T6
DESCRIPTION	-

DRAWING No.	SECTION No.
-	