

Model RABP156-01.PART [A]  
 Drawing RABP156-01.dwg

ID	Description	Date	By	Appr.
A	New 3D based profile drawing	01.07.2016	SPe	MSa

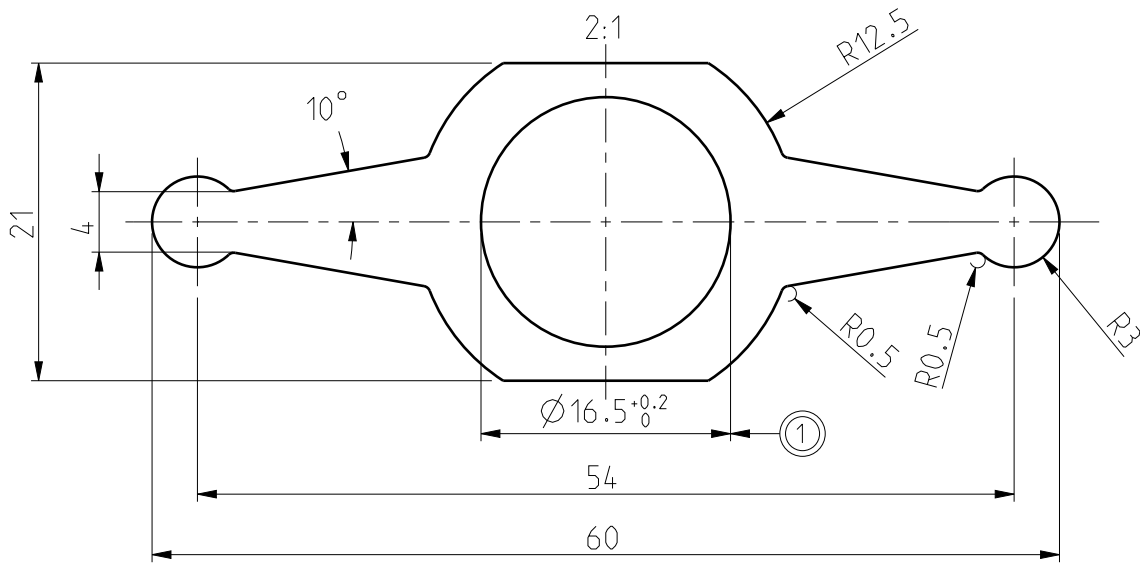

Hardness:	95-115HB
Tolerance:	SFS-EN 755-9

Symbol	Instruction of the Symbol	No. of Dim
	Basic Dimension. To be measured in full measurement of part	-
	Cpk dimension. To be measured in process capability study	-
	SPC dimension. To be measured during production	1

Note: All numbered dimensions are to be measured in full measurement

Part	Code	Description	Pcs	Weight (g)/pcs
Supplier:	Tool No:	Volume	Weight (g)	1
Material: EN AW - 6082 T6		Ensto Mat:		
 Ensto Finland Oy Ensto Utility Networks		 Wing nut profile	Replaces: 416021	
Scale 1:1 Date 28.06.16 A4			Replaced:	
By SPe Checked			Draw No: 000317149 A	
Sheet No: 1 (1) Ctrl			Ref: pss273	
			Code: rabp156.01	