

SECTION A-A

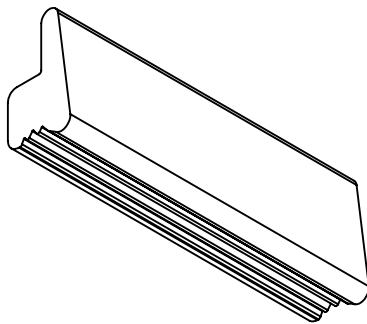

ISOMETRIC VIEW

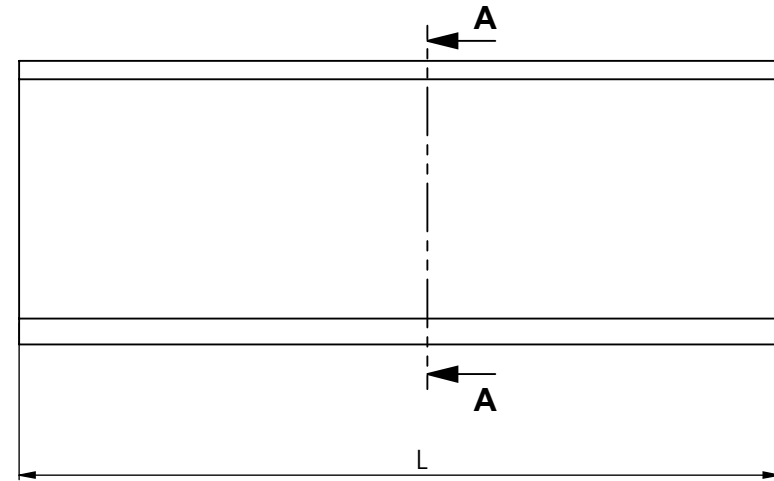
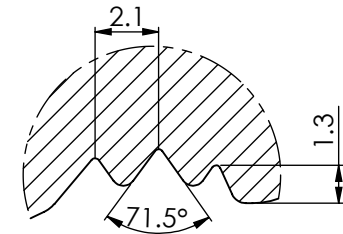

DETAIL X

PROCESS: EXTRUSION

		<h1>HORIZON AEROSPACE (INDIA) PVT. LTD.</h1>			
PROJECTION ANGLE: FIRST ANGLE SCALE : N.T.S. WEIGHT: --	QPA: --	ALL DIMENSIONS ARE IN MM UNLESS OTHERWISE SPECIFIED	DRAWN	CHECKED	APPROVED
	MATERIAL: AL- 6061-T6		KAMLESH	RASHID	P. BANSAL
GENERAL MFG.TOLERANCE: DIMENSIONS<15: +0.1, DIMENSIONS>15: J12 (SEE NF EN 20286) MACHINING ✓ SEE ISO 1302 BORE BOTTOM RADIUS, UNLESS OTHERWISE SPECIFIED: 0.5 NO SHARP CORNERS	MATERIAL CONDITION: --	THIS DRAWING IS THE PROPRIETARY OF M/S HORIZON AEROSPACE (INDIA) PVT. LTD. UNAUTHORIZED USE OF THIS DRAWING OR MAKING PRODUCT AS PER OUR DRAWING WITHOUT OUR PERMISSION OR ANY MISUSE IS NOT PERMITTED			
	FINISH: --	REF. NO.: R463L- PALLET	DATE: 21-08-2023	STD.: --	REVISION: --
DESCRIPTION: <h2 style="text-align: center;">STRAP STOPPER</h2>			DRAWING NO.: <h2 style="text-align: center;">27131900021</h2>		SHEET: 1 / 1