

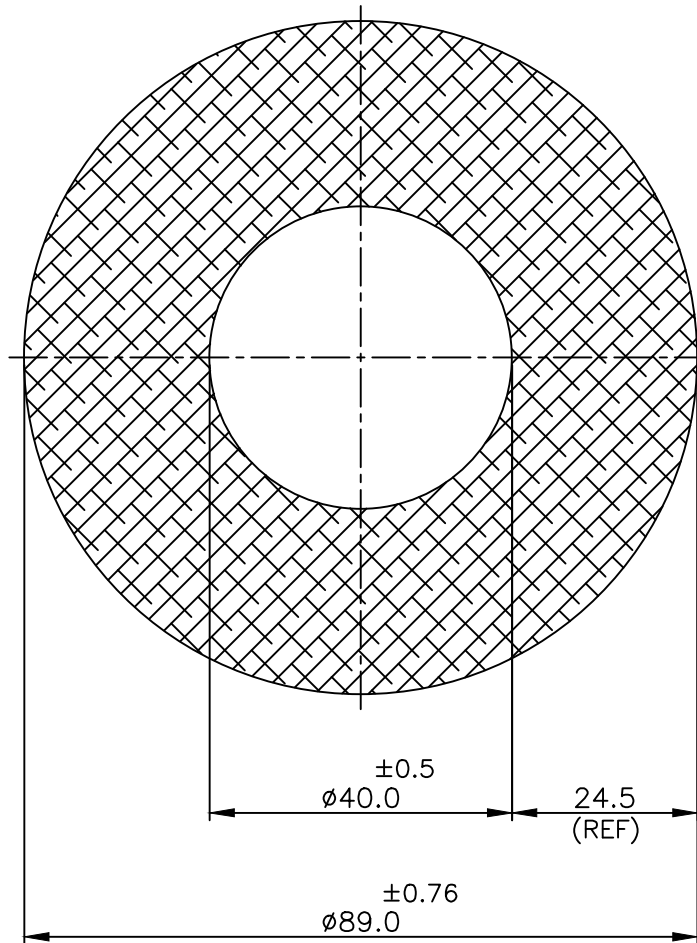

SCALE:- 1 : 1
ALL DIMENSIONS IN MM.



- NOTES.
 1. ALL ANGLES $\pm 2^\circ$
 2. UNSPECIFIED TOLERANCE ± 0.2
 3. TOLERANCE ON TWIST & BEND 1.7mm./M.

| | | | | | | |
|--|---------------|---|------------|-----------------------------|----------|------|
| SUDAL INDUSTRIES LIMITED | |  | | | | |
| | | | | | | |
| CUSTOMER:- ASSOCIATED ENGG. COMPANY CUSTOMER DRG. NO:- ----- PART NAME:- ----- | | | | | | |
| | | | | Sr.No | REVISION | DATE |
| C.C.D. | DIE FACTOR | DIE ORDER | Wt Kg./M. | CONTAINER DIA | DIE DIA | |
| 89.00 | 30 | - - - | 13.404 | 185 | 235 | |
| SEC. AREAmm ² | PERIMETER | EXT. RATIO | IMPRESSION | ALLOY-TEMP. | TYPE | |
| 4964.50 | 405.3 | 5 | 1 | 6351 T6 | HOLLOW | |
| DATE | DRAWN | CHECKED | APPROVED | SECTION NO. RT-30344 | | |
| 09.06.2006 | <i>Sanjay</i> | | | | | |