

BEFORE APPROVAL CHECK ALL DIMENSIONS PROPERLY

PROPOSED DRAWING

Q00450

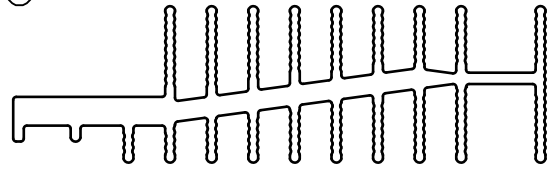

SCALE 1:1

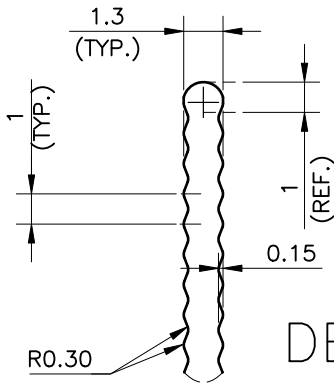
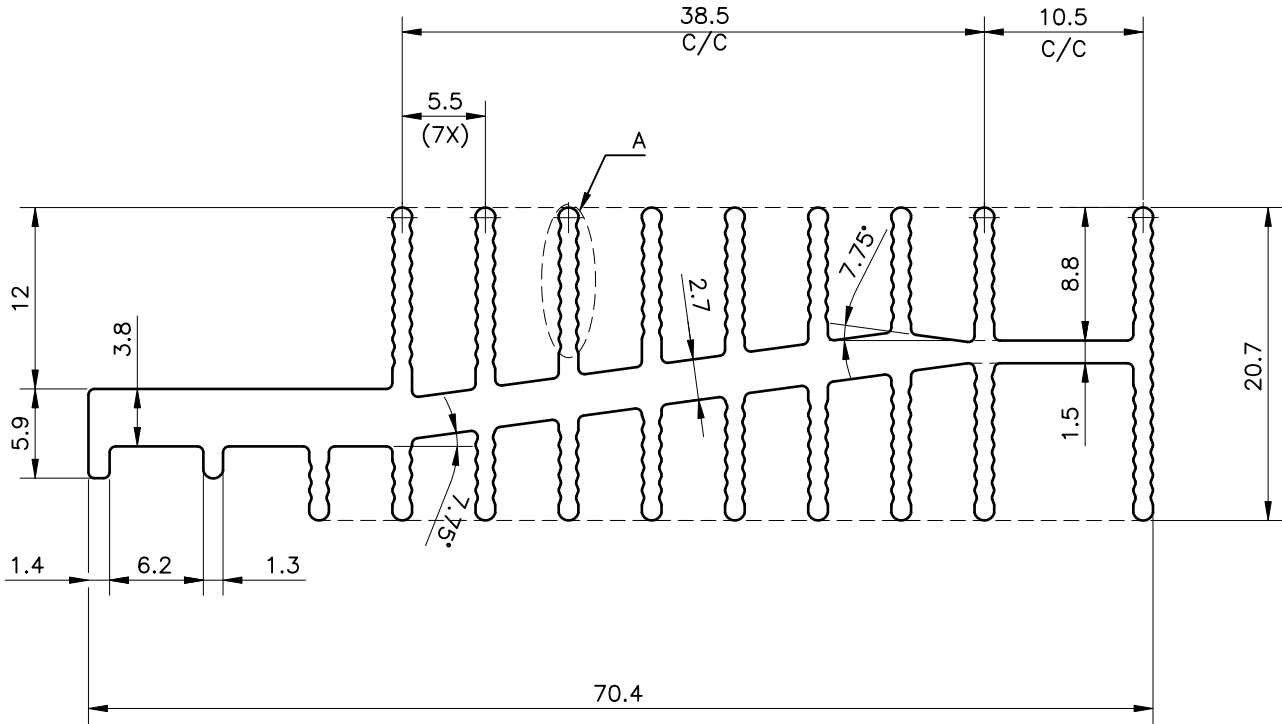

DETAIL A
SCALE 4:1



SYMBOL OF QUALITY
AN ISO 9001 COMPANY

JINDAL ALUMINIUM LTD.
BHIWADI-301019 (INDIA)

	NAME	DATE
DRAWN	ASHUTOSH	16-03-2023
CHECKED		
APPROVED		

1. ALL DIMENSIONS ARE IN mm.
2. ROUND OFF ALL SHARP CORNERS WITH 0.40 mm.
3. TOLERANCES WILL BE AS PER BS:EN-755-9 , UNLESS OTHERWISE SPECIFIED

SCALE	1:1&2:1
AREA mm ²	398.13
PERIMETER mm.	488.46
WEIGHT kg/m	1.075
DRAWING No.	SECTION No.

PARTY'S NAME	M/s. SHREE JAI KRISHEN INC.
PARTY'S DRAWING No.	AS PER DRAWING-Q00450
ALLOY & TEMPER	6063-T6
DESCRIPTION	HEAT-SINK