

BEFORE APPROVAL CHECK ALL DIMENSIONS PROPERLY

PROPOSED DRAWING

Q00453

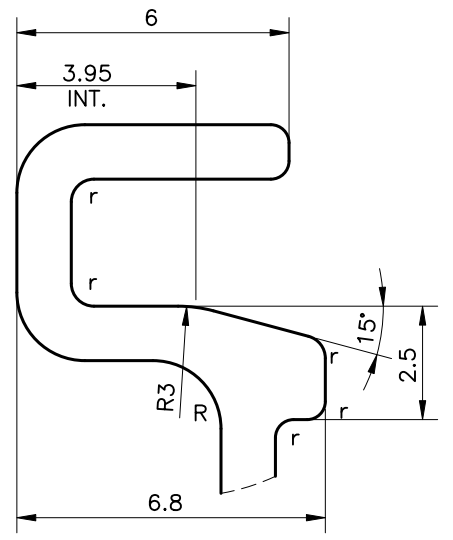
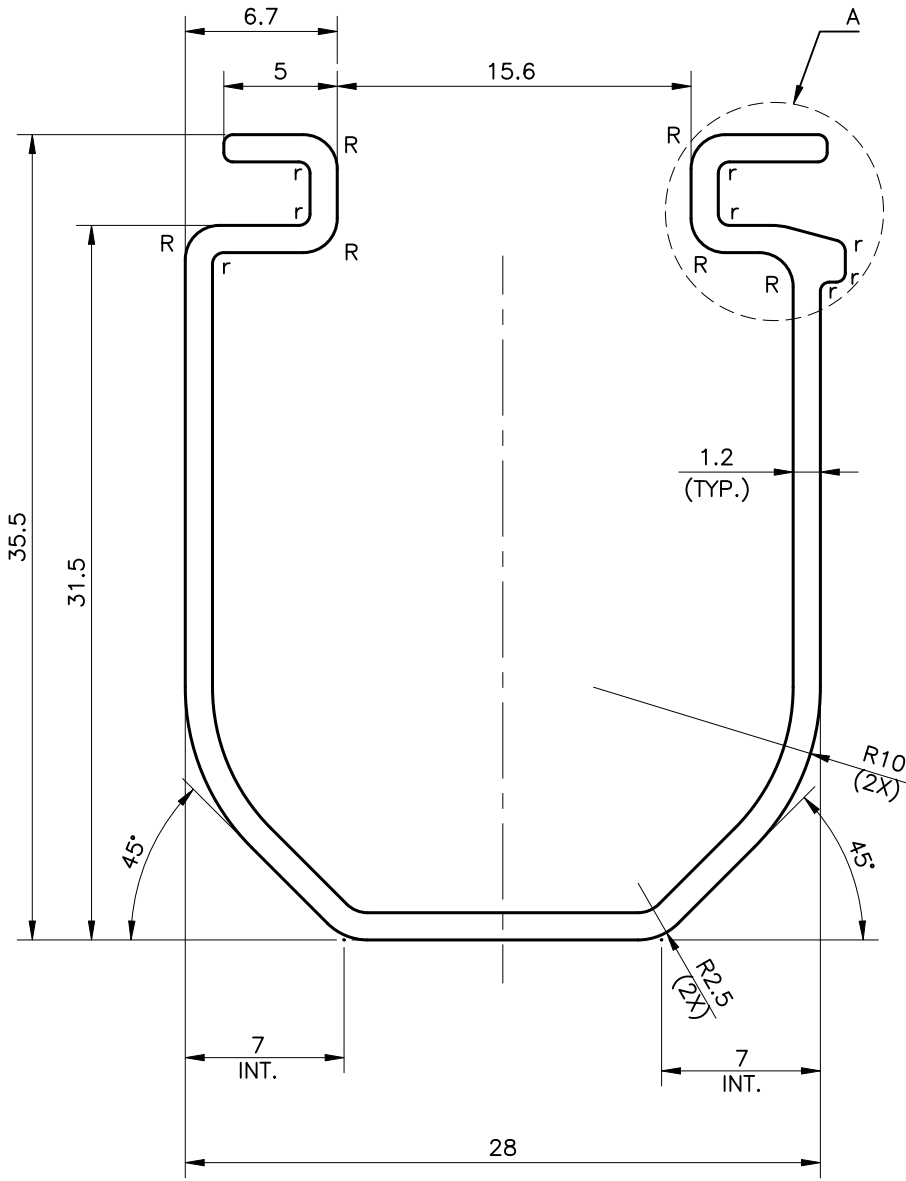
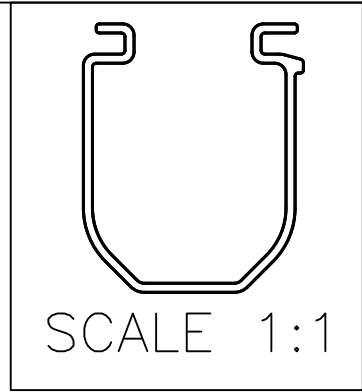

DETAIL A
SCALE 6:1

NOTE:
R=1.50R
r=0.50R



JINDAL ALUMINIUM LTD.
BHIWADI-301019 (INDIA)

	NAME	DATE
DRAWN	ASHUTOSH	26-03-2023
CHECKED		
APPROVED		

1. ALL DIMENSIONS ARE IN mm.
2. ROUND OFF ALL SHARP CORNERS WITH 0.40 mm.
3. TOLERANCES WILL BE AS PER BS:EN-755-9 , UNLESS OTHERWISE SPECIFIED

SCALE	1:1&3:1
AREA mm ²	127.55
PERIMETER mm.	210.73
WEIGHT kg/m	0.344
DRAWING No.	SECTION No.
-	

PARTY'S NAME	M/s. SWASTIKA AUTOMATICS
PARTY'S DRAWING No.	AS PER DRAWING-CASE-CCE3110071
ALLOY & TEMPER	6063-T6
DESCRIPTION	-