

BEFORE APPROVAL CHECK ALL DIMENSIONS PROPERLY

PROPOSED DRAWING

Q00454

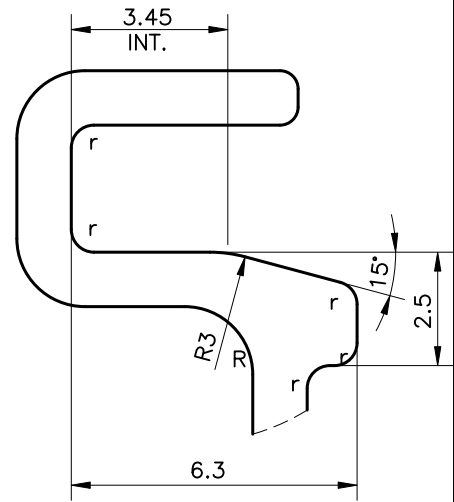
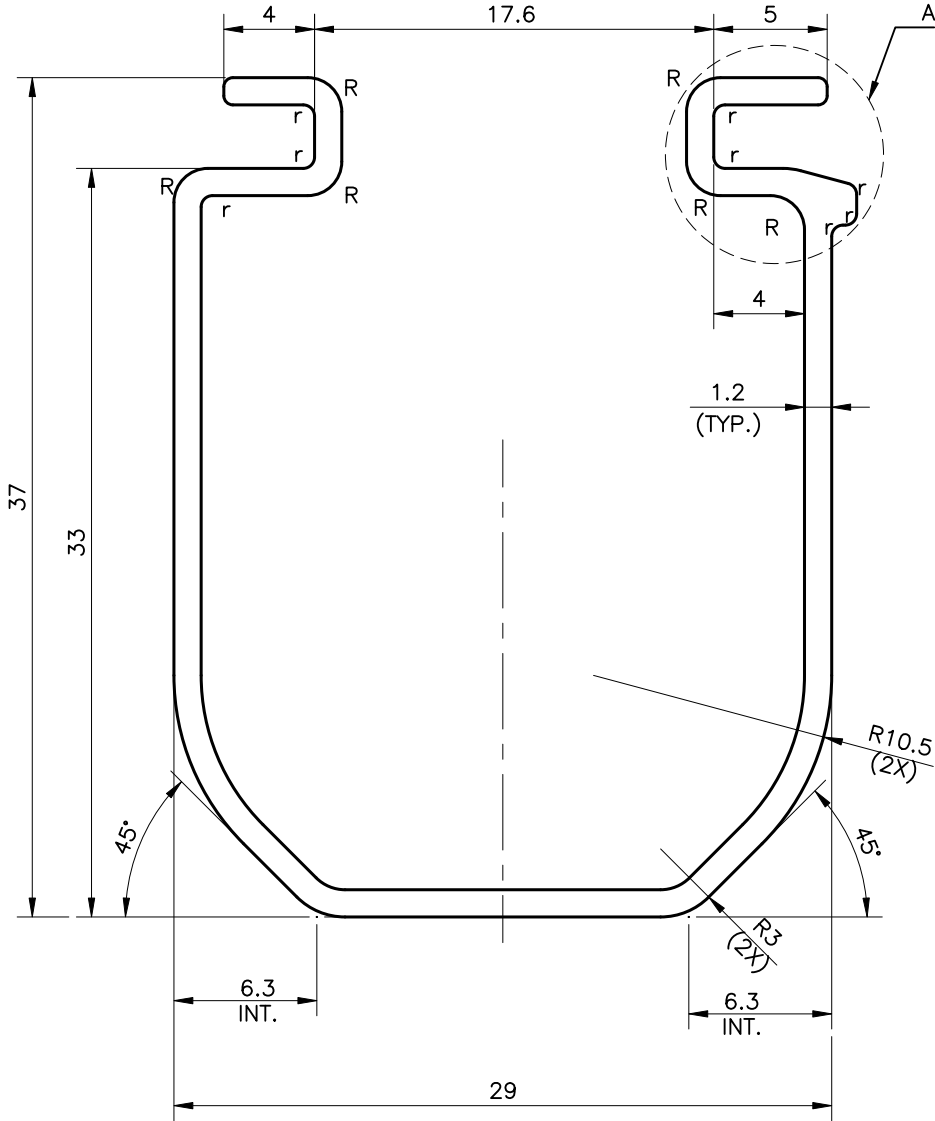
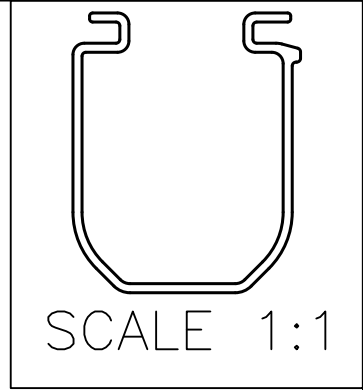

DETAIL A  
SCALE 6:1

NOTE:  
R=1.50R  
r=0.50R



SYMBOL OF QUALITY  
AN ISO 9001 COMPANY

**JINDAL ALUMINIUM LTD.**  
BHIWADI-301019 (INDIA)

	NAME	DATE
DRAWN	ASHUTOSH	26-03-2023
CHECKED		
APPROVED		

- ALL DIMENSIONS ARE IN mm.
- ROUND OFF ALL SHARP CORNERS WITH 0.40 mm.
- TOLERANCES WILL BE AS PER BS:EN-755-9 , UNLESS OTHERWISE SPECIFIED

SCALE	1:1&3:1
AREA mm <sup>2</sup>	135.39
PERIMETER mm.	223.71
WEIGHT kg/m	0.366
DRAWING No.	SECTION No.
-	

PARTY'S NAME	M/s. SWASTIKA AUTOMATICS
PARTY'S DRAWING No.	AS PER DRAWING CASING-HMC2TG-CCH311167Y
ALLOY & TEMPER	6063-T6
DESCRIPTION	-