

DRAWING NO. FGT/FFAP-E3/01/BP
 (SC) _____
 (CC) _____

M/C DEVIATION FOR OPEN DIMENSIONS (MED. TO IS :2102)								SPECIAL TOLERANCE	
ABOVE	0.5	3	6	30	120	315	1000	H7	+0.013
UPTO AND INCLUDING	3	6	30	120	315	1000	2000	XX.XXX	-0.000
MEDIUM	±0.1	±0.1	±0.2	±0.3	±0.5	±0.8	±1.2		

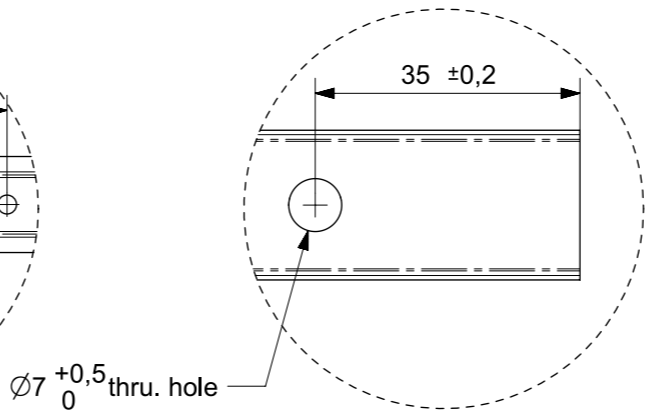
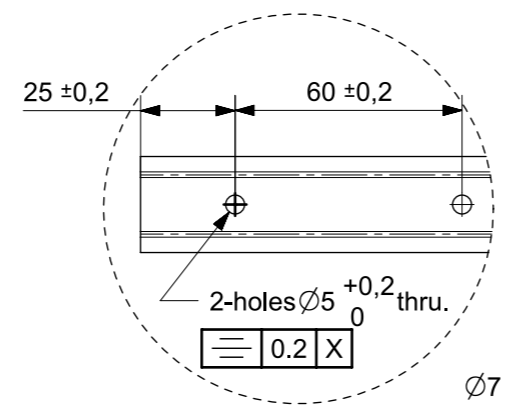
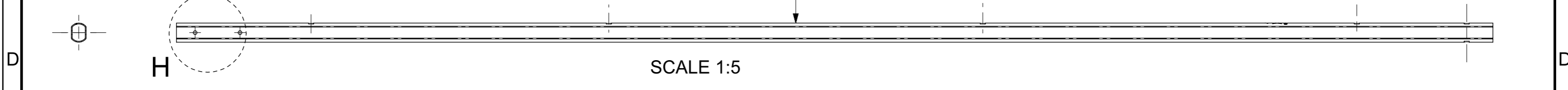
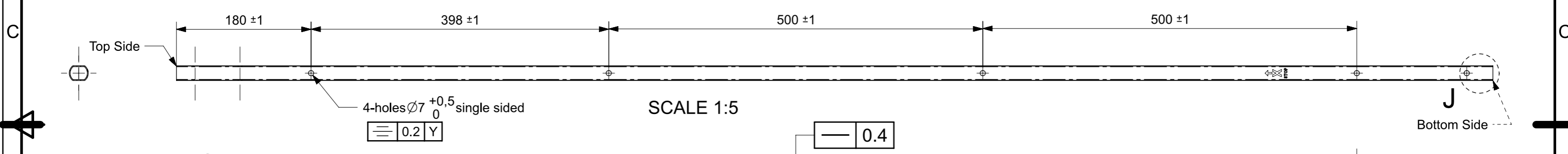
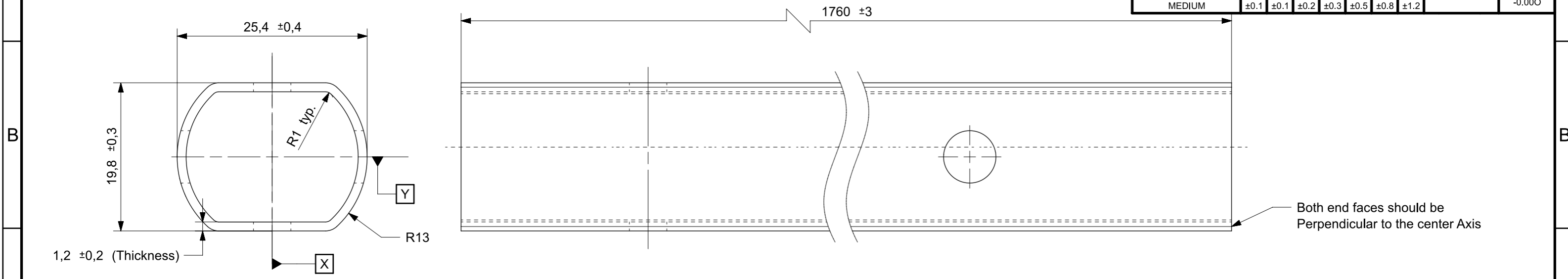

- NOTES:-
1. Component should be free of crack, deformation, scratch, rust and burr.
 2. For unspecified dimension follow the 3D model data.
 3. Surface Finish- Anodizing
 4. Surface Color- as per CFG.

REV.	DESCRIPTION			CHANGED BY	APPROVED BY	DATE
A4	NAME	SIGN	DATE			
DRAWN	DDS		13/02/23			
CHKD.	BS		13/02/23			
APPRD.	BS		13/02/23			
ASSLY. NAME		HEAT TREATMENT		SCALE		N.T.S.
FFAP-E3		T-6				
RAW MATERIAL		WEIGHT		QTY.		01 PER ASSLY.
ALU. ALLOY 6063		0.385 kg (Approx)		SHEET		1 OF 1
PART NAME		INNER TUBE		REV. NO.		00
				DRAWING NO.		FGT/FFAP-E3/01/BP
DIMENSIONS ARE IN MM UNLESS STATED OTHERWISE.						
THIS DRAWING IS THE SOLE PROPERTY OF FALCON GARDEN TOOLS. IT SHOULD NOT BE COPIED OR COMMUNICATED TO ANY PERSON WITHOUT WRITTEN APPROVAL OF COMPANY.						

