

UNSPECIFIED MACHINING DEVIATIONS

Latest Revision Available on Intranet Only

Upto 10	±1°	medium	±0.1	±0.2	±0.3	±0.5	±0.8	±1.2	±2.0	±3.0
10-50	±30'									
50-120	±20'									
Over 120	±10'									
Upto & including	6									
30										
120										
315										
1000										
2000										
4000										

X Area: 97.85 mm²

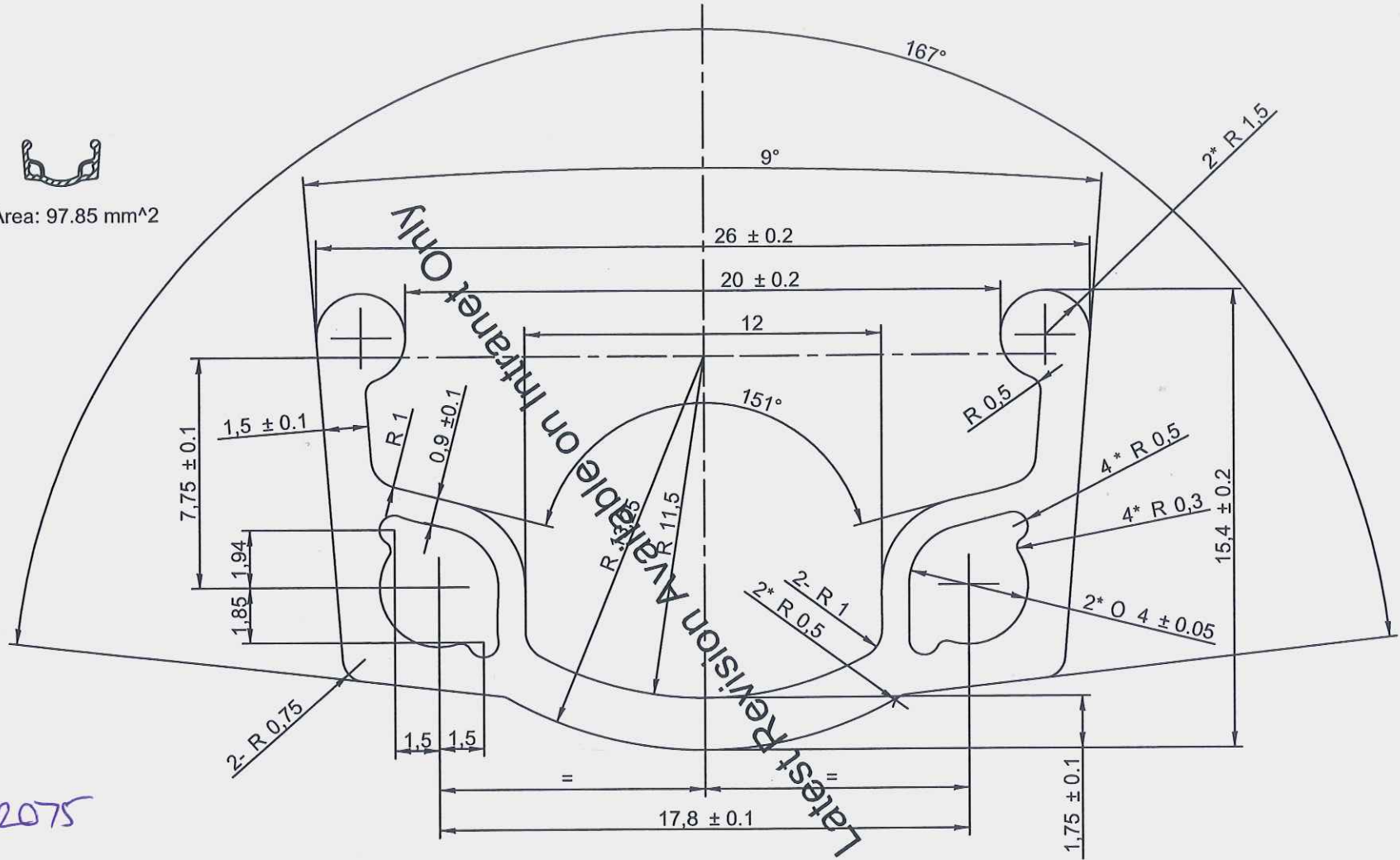

Q02075

No.	Alteration	Sign.	Date	Title :- Rim Profile, 26 x 20 x 15.4	Material:- 6061 - T6	DR,N	Kuldeep	30/08/12
				Scale : 10:1	Hardness :-	CHKD.		
				UNIT: mm A4		APPD.		
				General Tolerance: ISO : 2768 mK	Finish: Pre anodized	Model:	W/C REAR WHEEL	
				Forza Medi (I) Pvt.Ltd.		Ref Drawing No.	1426824-06	
						Drawing No.	FMI-C-0133	