

4442

19378

-



SCALE 1:1

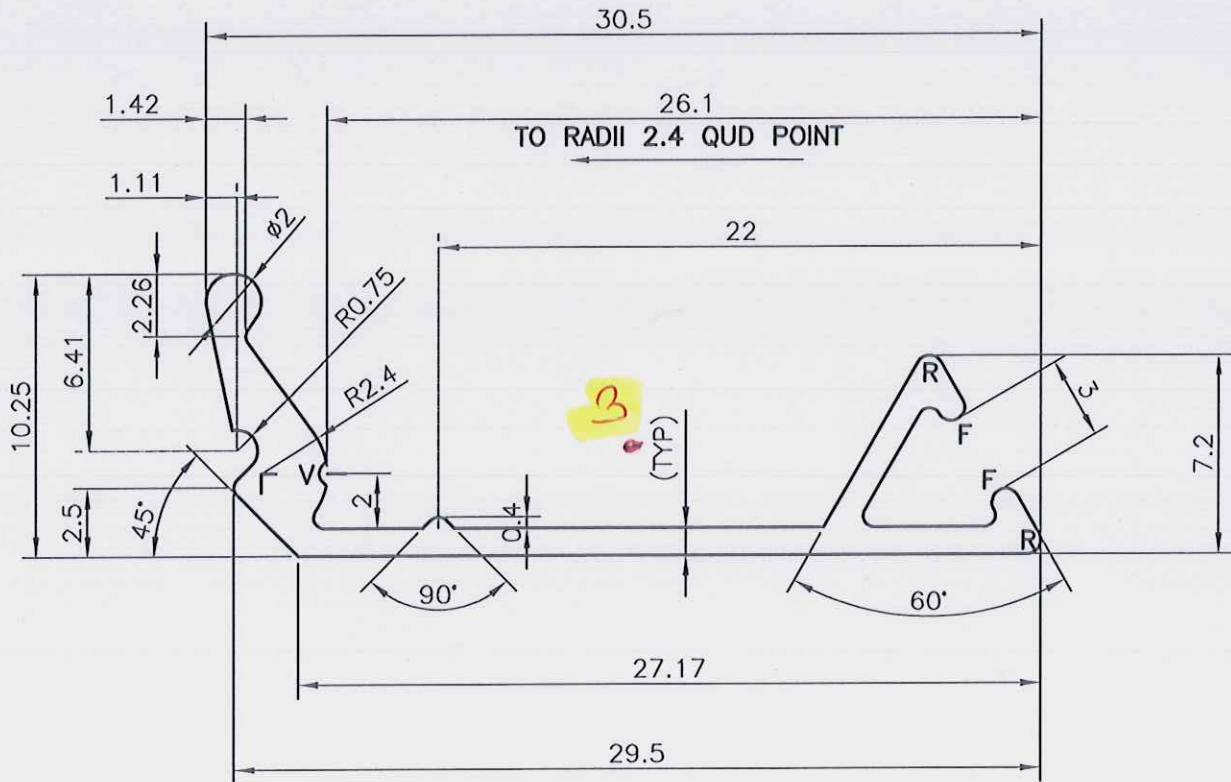

GENERAL WALL THICKNESS 1.00 mm

R = RADII 0.50 (2-PLACE)

F = RADII FULL (2-PLACE)

V = GROOVE 0.30x90° (1-PLACE) INCLUDING R0.30

Q00498



SYMBOL OF QUALITY
AN ISO 9001 COMPANY

JINDAL ALUMINIUM LTD.
BANGALORE-560073 (INDIA)

	NAME	DATE
DRAWN	PRASANNA.H.	13-12-2006
CHECKED		
APPROVED		
SCALE		4:1
AREA mm ²		57.512
PERIMETER mm.		95.295
WEIGHT kg/m		0.155
DRAWING No.	SECTION No.	
4442	-	
19378	19378	
-	-	

- ALL DIMENSIONS ARE IN mm.
- ROUND OFF ALL SHARP CORNERS WITH 0.40 mm.
- TOLERANCES WILL BE AS PER IS:3965-1981 UNLESS OTHERWISE SPECIFIED

PARTY'S NAME	RADHA SOAMI SATSANG BEAS, BEAS.	
PARTY'S DRAWING No.	AS PER SAMPLE (B.M. 20012)	
ALLOY & TEMPER	HE9 WP	
DESCRIPTION	GLAZING CLIP	