

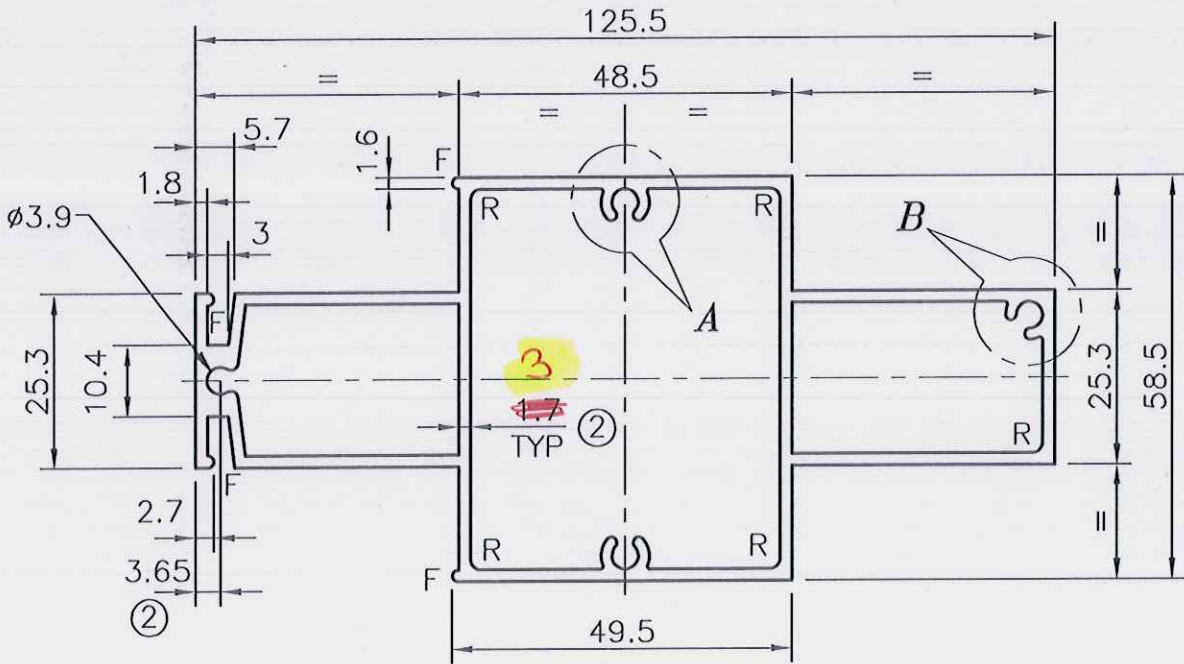

P-4176-1
9401
20996

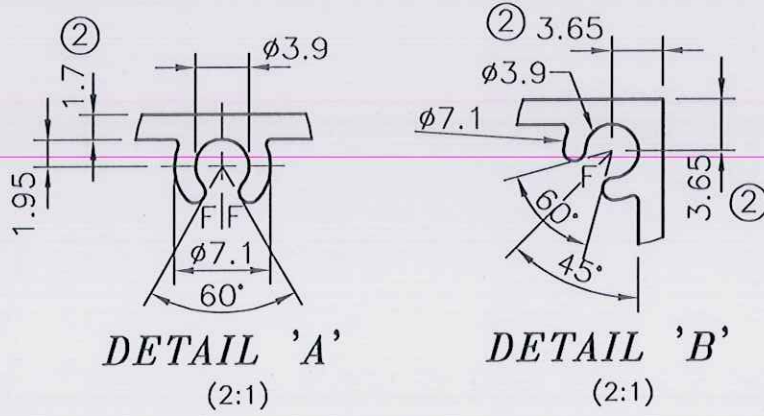

1. GENERAL WALL THICKNESS:- 1.70 mm.
2. F = FULL RADIUS (10)
3. R = 1.50 RADIUS (5)

ISSUE-2 CENTRE RIBS ADDED
WALL THICKNESS CHANGED FROM 1.8 TO 1.7mm
WEIGHT ALSO CHANGED FROM 1.994kg/M TO 2.102kg/M

200499

 SYMBOL OF QUALITY AN ISO 9001 COMPANY	JINDAL ALUMINIUM LTD. BANGALORE-560073 (INDIA)	NAME	DATE
		DRAWN	RAGHAVENDRA 08-06-2007
		CHECKED	
		APPROVED	
		SCALE	1:1
		AREA mm ²	778.502
		PERIMETER mm.	400.79
		WEIGHT kg/m	2.102
PARTY'S NAME	RADHA SOAMI SATSANG BEAS, BEAS	DRAWING No.	SECTION No.
PARTY'S DRAWING No.	AS PER SAMPLE (BM-20070)	P-4176-1	-
ALLOY & TEMPER	HE9 WP	9401	9401
DESCRIPTION	WINDOW CENTRE MULLION	20996	20996-ISSUE-2