

S556
 9304
 12550
 20900

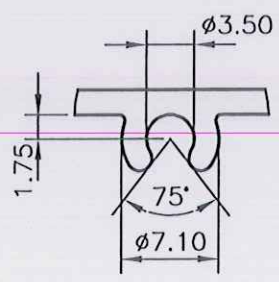

TYPICAL DETAIL

(2:1)

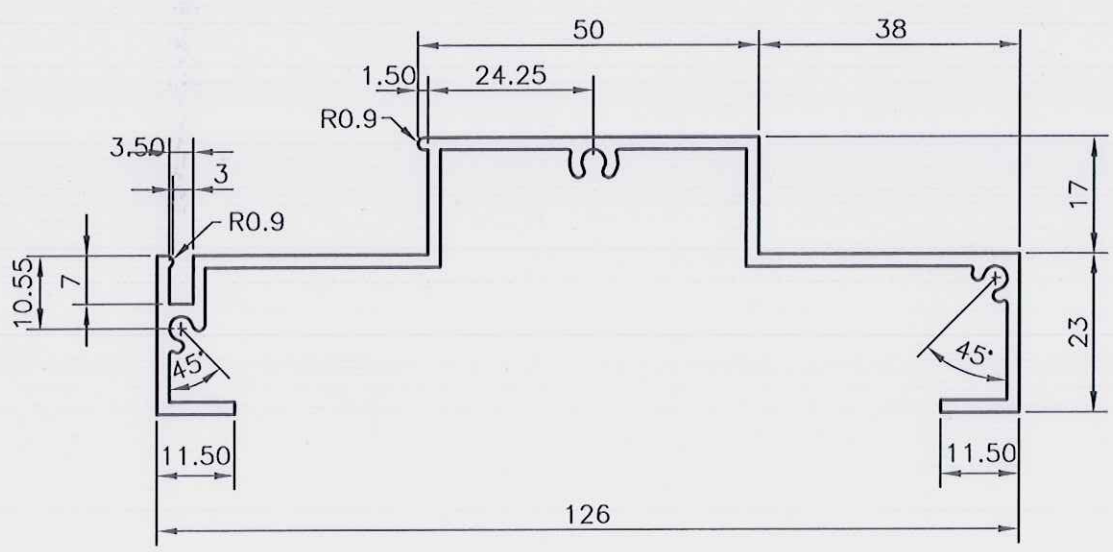

1. GENERAL WALL THICKNESS :- ~~1.80~~ ³ mm.

Q00500

 SYMBOL OF QUALITY AN ISO 9002 COMPANY	JINDAL ALUMINIUM LTD. BANGALORE-560073 (INDIA)		NAME	DATE
		DRAWN	R.D.Sharma	06-08-2000
1. ALL DIMENSIONS ARE IN mm. 2. ROUND OFF ALL SHARP CORNERS WITH 0.40 mm. 3. TOLERANCES WILL BE AS PER IS 3965-1981 UNLESS OTHERWISE SPECIFIED		CHECKED		
		APPROVED		
		SCALE	1:1	
PARTY'S NAME	RADHA SOAMI SATSANG BEAS, BEAS	WEIGHT kg/m	1.207	
PARTY'S DRAWING No.	NIL (B.M.20008) (OLD)	SECTION No.	20900	
ALLOY & TEMPER	HE9 WP	DRAWING No.	20900	
DESCRIPTION	WINDOW FRAME			