

P-10906-2

S2968

21667

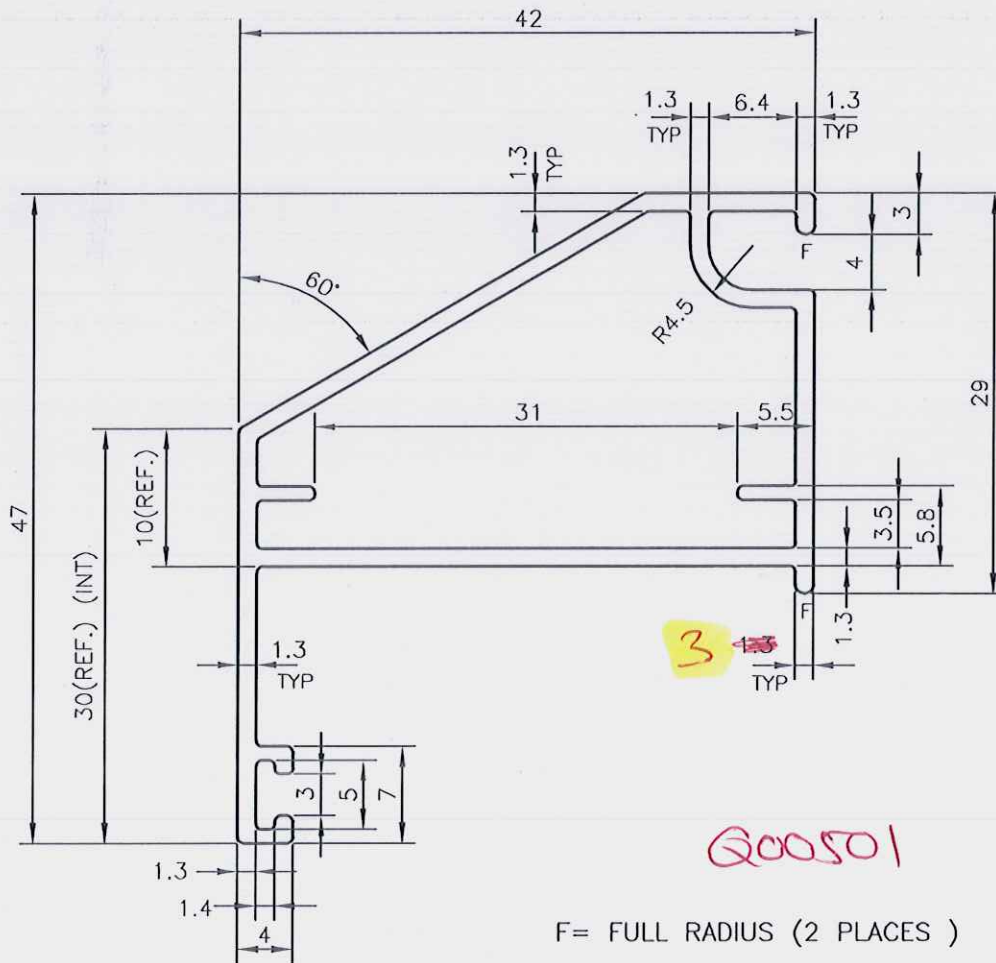
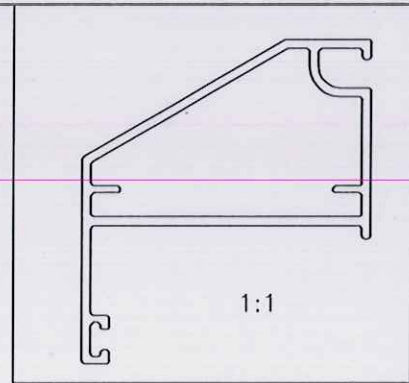

SYMBOL OF QUALITY
AN ISO 9001 COMPANY

JINDAL ALUMINIUM LTD.
BANGALORE-560073 (INDIA)

	NAME	DATE
DRAWN	J.P.KAUSHIK	10-05-2011
CHECKED		
APPROVED	S.S.GARG	09-06-2011
SCALE		2:1
AREA mm ²		210
PERIMETER mm.		197.528
WEIGHT kg/m		0.569
DRAWING No.	SECTION No.	
P-10906-2	-	
S2968	S2968	
21667	21667	

1. ALL DIMENSIONS ARE IN mm.
2. ROUND OFF ALL SHARP CORNERS WITH 0.40 mm.
3. TOLERANCES WILL BE AS PER IS:6477-1983 UNLESS OTHERWISE SPECIFIED

PARTY'S NAME	DG-MAP, NEW DELHI
PARTY'S DRAWING No.	DGM-16
ALLOY & TEMPER	HE9 WP
DESCRIPTION	WINDOW SECTION (WIREMESH SHUTTER)