

Scale 2:1

Finish Surface

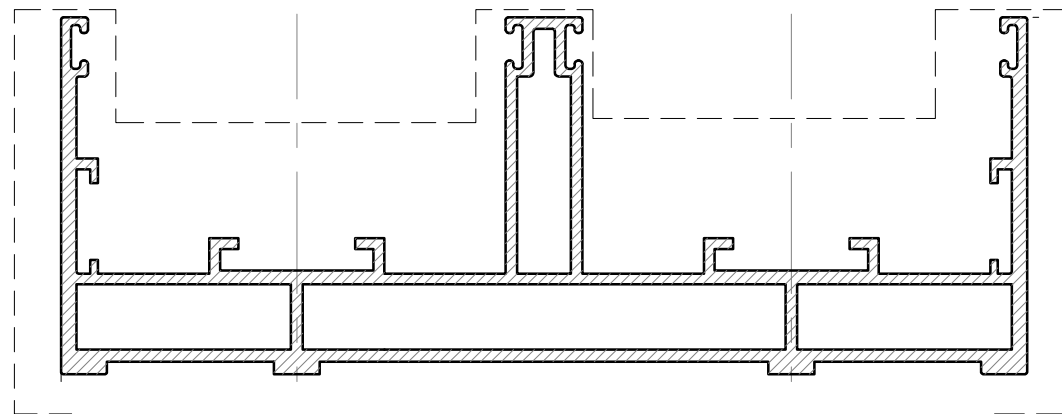

Scale 1:1

Special Feature:-

1. Anodizable.
2. No Machining
3. To Bend- No
4. Alloy & Temper - 6063 T6

Cut Length :- ??

Note- All sharp edge radius is 0.2 mm.

W = 2.162 Kg/M

Material.- AL (6063 T6)	Qty-	Extrusion Aluminium 46.5x126 GS35-2T-Outer				
Customer		Project				
GSC Alusystems Private Ltd Plot 41, Sector Ecotech-1, Extension-1, Greater Noida, Gautam Buddha Nagar UP, India Pin 201310		Print: Draft	Drg No: M33921			
Drawn By AKS	Date 10/10/2023	Version Rev.A6	Scale 1:1	Format A3	Sheet 1/1	
File: D:\USERS\Alok\Alusystems Development\GS35\GS35(NEW) RevA6.dwg						