

SCALE 1:1

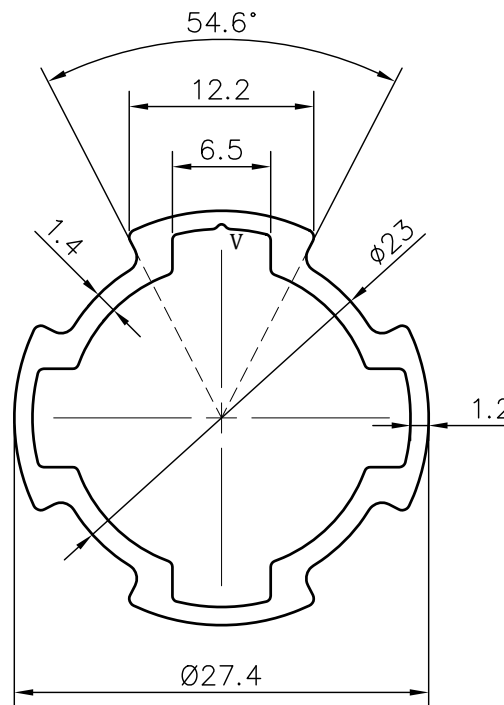

SCALE 2:1

Area: 138.254 Sq.mm.
Perimeter: 93.271 mm.
Weight: 0.373 Kg./mtr.

NOTE:-
V= 0.30x90° V-GROOVE (1 PLACE)

PHOENIX MECANO INDIA PVT. LTD., GURUGRAM
SAMPLE DRAWING



SYMBOL OF QUALITY
AN ISO 9001 COMPANY

JINDAL ALUMINIUM LTD.
BHIWADI-301019 (INDIA)