

...es have to be defined.  
**COMPRESSION STIFFNESS TESTING**

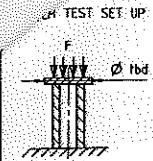

**TEST MACHINE SET-UP**

MAX. ERROR FORCE	$F_v$	$\pm 1$ kN
MIN. RESOLUTION DISPLACEMENT	$F_d$	0,5 μm
TEST MACHINE STIFFNESS	$C_v$	$\geq 200$ kN/mm

... means effective test machine stiffness and test set up stiffness by use of software.

**TEST PARAMETERS**

MEASURING SPEED	$V_v$	2 mm/min
PRELOAD	$F_p$	1 kN
TEST LOAD 1	$F_1$	64 kN
TEST LOAD 2	$F_2$	96 kN
TEST LOAD 3	$F_3$	64 kN
HOLDING TIME AT $F_3$	$\Delta t$	5 sec

**REQUIREMENTS**

COMPRESSION  $SC | s_1 - s_2 \leq 0.14$  mm

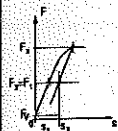

BLOCK 1

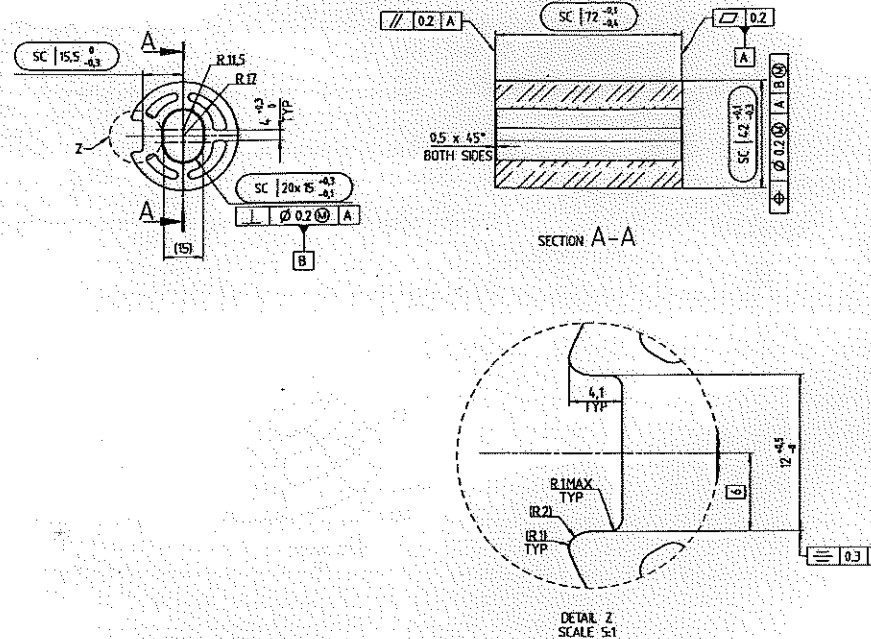

REV./CHG	FIELD	REV. NO.	CHANGE DESCRIPTION	DATE	NAME
A			INITIAL RELEASE	28.04.2023	Kumar, Veyar

**NOTE :**

- PART MUST COMPLY WITH THE REQUIREMENTS OF EN 8 & HAZARDOUS MATERIAL CONTENT AS SPECIFIED IN M&M STANDARD 4001474 (REV-2), AS PER THE MARKET REQUIREMENTS. IN CASE OF MULTIPLE MARKETS, PART MUST COMPLY WITH ALL LEGISLATIVE REQUIREMENTS OF THE RESPECTIVE MARKET.
- DEFAULT PROFILE:  $\sqrt{Rz60}$

BLOCK 2

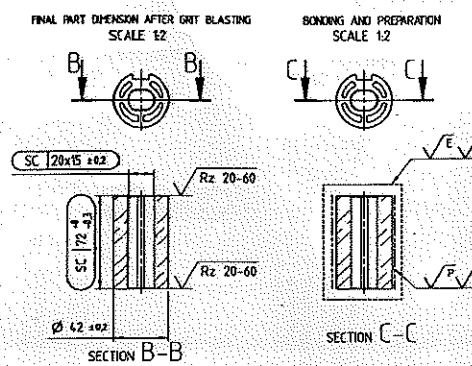

**\* PREPARATION TABLE**

CONDITION	SYMBOL	SPECIFICATION	REFERENCE STANDARD	RESPONSIBLE
PREPARATION ITEM		DETAILED SPECIFICATION IN THIS AREA. IF NO REFERENCE STANDARD OR SPECIAL RESTRICTION IS EMPHASIS IS MADE ON SOME CHARACTERISTICS.	RELATED REFERENCE STANDARD	DEFIN. RESPONSIBLE
DELIVERY		ISFC FREE FROM ALL POSSIBLE CONTAMINANTS THAT COULD NOT BE REMOVED BY STANDARD VVC DEGREASING PROCESS.	OP: 01-74-0066	COMPONENT SUPPLIER
PREPARATION SURFACE	DEPREASING	✓ E ALKALINE WASH	TES-2002.2 Rev.7	BONDING SUPPLIER
GRIT BLASTING	✓ S	STEEL SHOT	TES-2002.1 Rev.7	BONDING SUPPLIER
PRIMER	✓ P	ETHERKOC 205	TES-2002.1 Rev.7	BONDING SUPPLIER
COVER	✓ C	CHEMKOC 6411	TES-2002.1 Rev.7	BONDING SUPPLIER

**PREPARATION AREA MARKED:**

IF NEEDED, ADHESIVE THICKNESS CONTROL ON DEFINED AREA - ADHESIVE THICKNESS GAUGE AREA

IF NEEDED, TREATMENT THICKNESS CONTROL ON DEFINED AREA - TREATMENT THICKNESS GAUGE AREA

IF NEEDED, ROUGHNESS CONTROL ON DEFINED AREA - ROUGHNESS GAUGE AREA

	ALUMINIUM	STEEL
INCREASE OF LENGTH (mm)	-0.1	-0.05
BORE DIMENSION (mm)	-0.1	-0.05
INCREASE OF OUTER Ø (mm)	-0.1	-0.05

**\* TO BE DEFINED / FINALISED AFTER RESULTS OF PRODUCTION PARTS**

AS NECESSARY MARKING MUST APPEAR IN LOCATION NOTED ON DRAWING AND SHOULD BE READABLE

PART MUST BE FREE OF BURRS, SHARP EDGES OR FLASHING WHICH MAY BE DETRIMENTAL TO SATISFACTORY ASSEMBLY, SAFE HANDLING, APPEARANCE OR FUNCTION

THIS PRINT SUPERSEDES ALL INDUSTRY STANDARDS NOT SHOWN

FEATURES FOR MANUFACTURING PURPOSES PERMISSIBLE PER VIBRACOUSTIC ENGINEERING APPROVAL

FOR FEATURES WITHOUT DIMENSION REFER TO 3D MODEL

NO CHANGES ALLOWED WITHOUT VIBRACOUSTIC APPROVAL

**SPECIAL CHARACTERISTICS**

CC/C/AS/SC/EC

ACC. TO GP-01-74-0907

1-0.3  $\sqrt{Rz60}$

GENERAL TOLERANCES		DATE		DATE	NAME	STATUS
UNLESS OTHERWISE SPECIFIED		DATE	25.04.2023	25.04.2023	Kumar, Veyar	IN AN-4005 (15)
		DESIGNED BY	11.07.2023	11.07.2023	Singh, Gurwinder	IS PER 44755-2
		APPROVED BY	11.07.2023	11.07.2023	Sanjivan, Meevan	
		RELEASE STATUS			designed	
LAST SENT WITH PRODUCTION DRAWING	SIGHT METAL ALLOY	ALUMINIUM FINISH	OR DR 584-3			
GRAY CAST IRON	60 S&M 3	DRIP FORMING	OR DR 584-3			
100 MAG. 4	CTC 4	OR DR 584-3	FORMING RANGE 6			
100 MAG. 5	CTC 5	OR DR 584-3				
100 MAG. 6	CTC 6	OR DR 584-3				
100 MAG. 7	CTC 7	OR DR 584-3				
100 MAG. 8	CTC 8	OR DR 584-3				
100 MAG. 9	CTC 9	OR DR 584-3				
100 MAG. 10	CTC 10	OR DR 584-3				
100 MAG. 11	CTC 11	OR DR 584-3				
100 MAG. 12	CTC 12	OR DR 584-3				
100 MAG. 13	CTC 13	OR DR 584-3				
100 MAG. 14	CTC 14	OR DR 584-3				
100 MAG. 15	CTC 15	OR DR 584-3				
100 MAG. 16	CTC 16	OR DR 584-3				
100 MAG. 17	CTC 17	OR DR 584-3				
100 MAG. 18	CTC 18	OR DR 584-3				
100 MAG. 19	CTC 19	OR DR 584-3				
100 MAG. 20	CTC 20	OR DR 584-3				
100 MAG. 21	CTC 21	OR DR 584-3				
100 MAG. 22	CTC 22	OR DR 584-3				
100 MAG. 23	CTC 23	OR DR 584-3				
100 MAG. 24	CTC 24	OR DR 584-3				
100 MAG. 25	CTC 25	OR DR 584-3				
100 MAG. 26	CTC 26	OR DR 584-3				
100 MAG. 27	CTC 27	OR DR 584-3				
100 MAG. 28	CTC 28	OR DR 584-3				
100 MAG. 29	CTC 29	OR DR 584-3				
100 MAG. 30	CTC 30	OR DR 584-3				
100 MAG. 31	CTC 31	OR DR 584-3				
100 MAG. 32	CTC 32	OR DR 584-3				
100 MAG. 33	CTC 33	OR DR 584-3				
100 MAG. 34	CTC 34	OR DR 584-3				
100 MAG. 35	CTC 35	OR DR 584-3				
100 MAG. 36	CTC 36	OR DR 584-3				
100 MAG. 37	CTC 37	OR DR 584-3				
100 MAG. 38	CTC 38	OR DR 584-3				
100 MAG. 39	CTC 39	OR DR 584-3				
100 MAG. 40	CTC 40	OR DR 584-3				
100 MAG. 41	CTC 41	OR DR 584-3				
100 MAG. 42	CTC 42	OR DR 584-3				
100 MAG. 43	CTC 43	OR DR 584-3				
100 MAG. 44	CTC 44	OR DR 584-3				
100 MAG. 45	CTC 45	OR DR 584-3				
100 MAG. 46	CTC 46	OR DR 584-3				
100 MAG. 47	CTC 47	OR DR 584-3				
100 MAG. 48	CTC 48	OR DR 584-3				
100 MAG. 49	CTC 49	OR DR 584-3				
100 MAG. 50	CTC 50	OR DR 584-3				

**Vibracoustic**

DESCRIPTION: CORE

SCALE: 1:1

DATE: 11.07.2023

REVISION: A

DRAWING NUMBER: XC-FA04.00-301

REV. SHEET: A/1

THE REPRODUCTION, DISTRIBUTION AND UTILIZATION OF THIS DRAWING AS WELL AS OTHERS WITHOUT EXPRESS AUTHORIZATION IS PROHIBITED. OFFICES WILL BE HELD LIABLE FOR THE RETURN OF DRAWING. ALL RIGHTS RESERVED BY THE HOLDER OF PATENT AND/OR OTHER INTELLECTUAL PROPERTY RIGHTS.