

Q01049

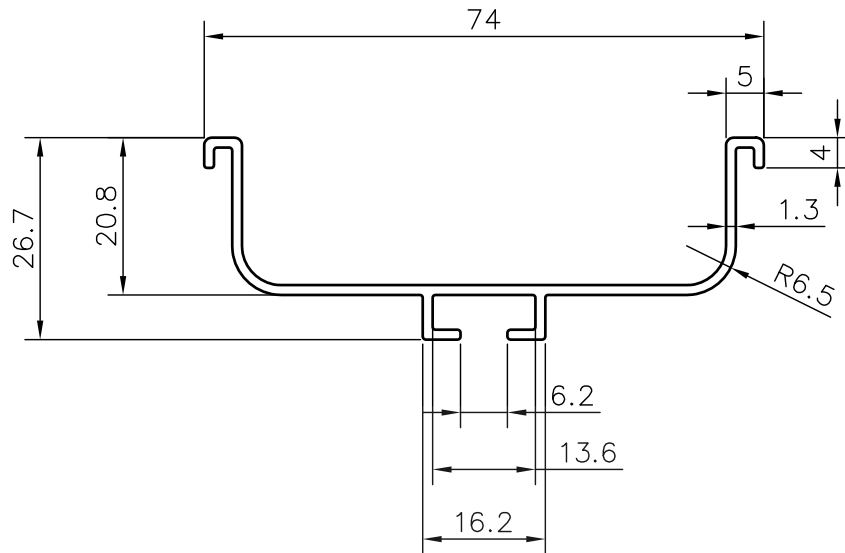

Area: 171.493 Sq.mm. | Perimeter: 262.61mm. | Weight: 00.463 Kg./mtr.

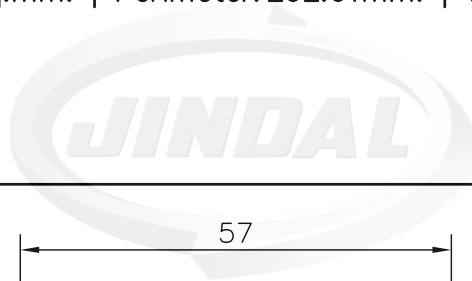

Q01050

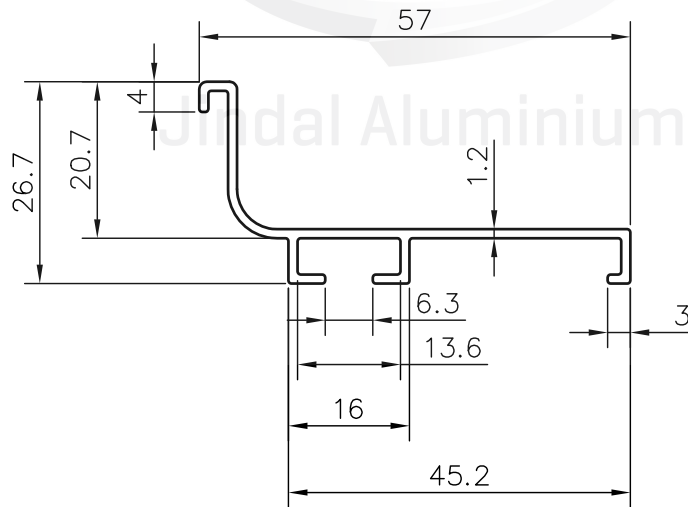

Area: 124.143 Sq.mm. | Perimeter: 205.5mm. | Weight: 00.335 Kg./mtr.

RANJAN KHOSLA & SONS PVT. LTD.
PROPOSED DRAWING



SYMBOL OF QUALITY
AN ISO 9001 COMPANY

JINDAL ALUMINIUM LTD.
BHIWADI-301019 (INDIA)