

版权所有，未经联大书面同意，不得以任何手段使用、复制或传递图纸。  
 This drawing shall not be used, reproduced or passed on in any way, in full or in part, without Lianda written approval. All rights reserved.

区 ZONE	版本 REV.	修改描述 MODIFICATION DESCRIPTION	日期 DATE	姓名 NAME
	X00			ChrisZhao
A3	X01	25.4 changed to 25.2±0.2	18/6/26	ChrisZhao

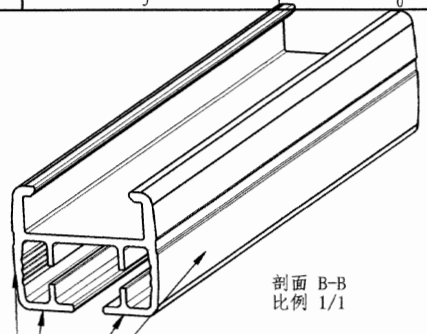
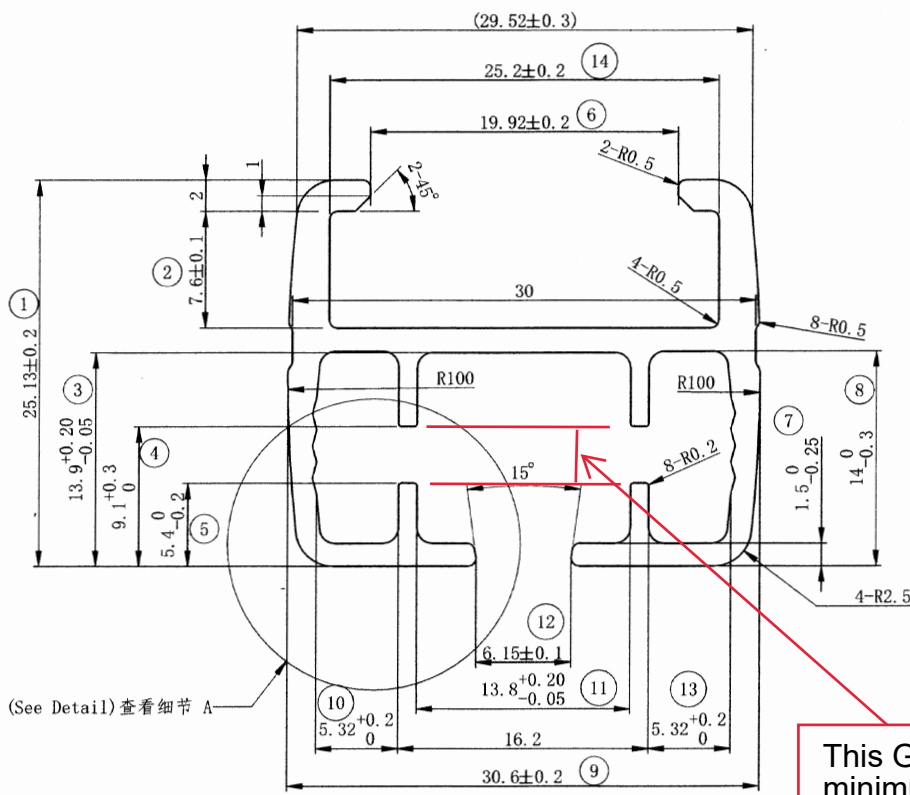

剖面 B-B  
比例 1/1

- 技术要求:
- 零件外形,未注尺寸,脱模斜度等以提供的三维数据为准;
  - 未注公差均按右下表;
  - 模具的型腔表面处理,抛光或细火花纹或者皮纹号另行通知;
  - 材料: 6063-T52 或 6063-T64
  - 产品必须符合RoHS要求;
  - 零件必须无飞边,划痕,流痕,缩薄,充填不满等缺陷;
  - 图纸中标有编号的是关键尺寸,总: 14个;
  - 轨道表面电泳处理,电泳层必须均匀,不能漏底;电泳颜色: 银色,参照样品
  - 轨道包装必须三面覆膜,如上图所示,并且膜撕去后不可以有胶残留
  - 油漆质量标准:  
在25厘米半径弯曲钢轨后,油漆不得开裂、断裂或剥落。  
涂料必须承受cross-hatch试验.约2平方,不允许剥落  
弯曲轨后,尺寸必须在±50毫米  
不得超过3扭曲变形/米

This Gap will be minimum 4.5 mm.  
(Both Side)

- NOTES
- ALL UNSPECIFIED DIMENSIONS, PLEASE REFER TO THE 3D FILE;
  - ALL UNSPECIFIED LINEAR TOLERANCES, PLEASE REFER TO RIGHT TABLE
  - THE SURFACE TREATMENT OF MOULDING NEED BE INFORM BY US;
  - MATERIAL : 6063-T52 OR 6063-T64
  - PARTS MUST COMPLY WITH ROHS;
  - PART MUST BE FREE OF FLASH, SINK, FLOW MARKS AND OTHER MOULDING ;
  - THE DIMENSION WITH "NUMBER" IS CRITICAL, TOTAL:13
  - TREATMENT OF RAIL SURFACE LAYER ELECTROPHORESIS, ELECTROPHORESIS MUST BE UNIFORM, CAN NOT LEAK; ELECTROPHORESIS COLOR: SILVER, REFER TO SAMPLE
  - THE PACKING MUST BE COVERED WITH PLASTIC FILM OF THREE SIDES, AS SHOWN ABOVE, AND NO GLUE RESIDUE AFTER PEELED OFF.
  - PAINT QUALITY CRITERIA:  
-PAINT MAY NOT CRACK, BREAK OR PEEL AFTER BENDING RAIL ON 25 CM RADIUS.  
-PAINT MUST WITHSTAND CROSS-HATCH TEST. APPROX 2MM SQUARES, NO FLAKING ALLOWED.  
-AFTER BENDING RAIL, DIMENSIONS MUST BE WITHIN +/- .50MM AT BEND AND MUST NOT EXCEED 3 TWIST/METER

备注: 轨道长度按5M/根切割包装, 每6根一包  
REMARK: THE TRACK LENGTH IS CUT BY 5M/PCS, EACH 6 PCS IN ONE PACK

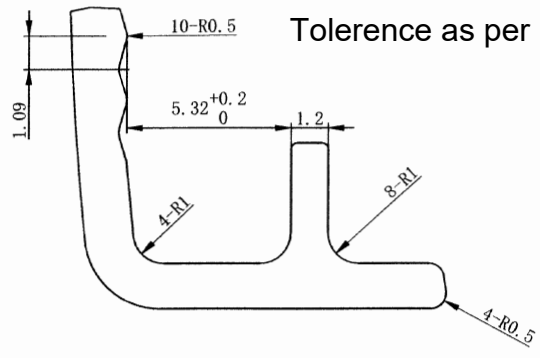

细节 (Detail) A  
比例 (Scale) 6/1

Tolerance as per BS:EN 755-9 only.

APPROVALS		DATE	材料 / MATERIAL 6063-T52 or 6063-T64	联大 Lianda
设计: Design:	Chris Zhao	2018/07/31	-	
审核: Examined/Verify	<i>[Signature]</i>	7.31.	热处理 HEAT TREATMENT	
会签: Countersign:			表面处理: ANODIZING	T5 ±0.15-0.10 ±0.10 T6 ±0.15 T5-T6 ±0.15 T6-T5 ±0.15 T5-T6 ±0.15 T5-T6 ±0.15 T6-T5 ±0.15 T5-T6 ±0.15
会审: Joint Meeting:				
批准: Approve:	<i>[Signature]</i>	07/31		
名称: DESIGNATION:	5M-轨道 5M-RAIL			比例 / SCALE : 3/1
				N : 5039831 A 00