

版权所有，未经联大书面同意，不得以任手段使用、复制或传播。 受版权保护。 此图不得在未经联大书面批准的情况下，以任何方式，在全部或任何部分中，复制或传播。 保留所有权利。

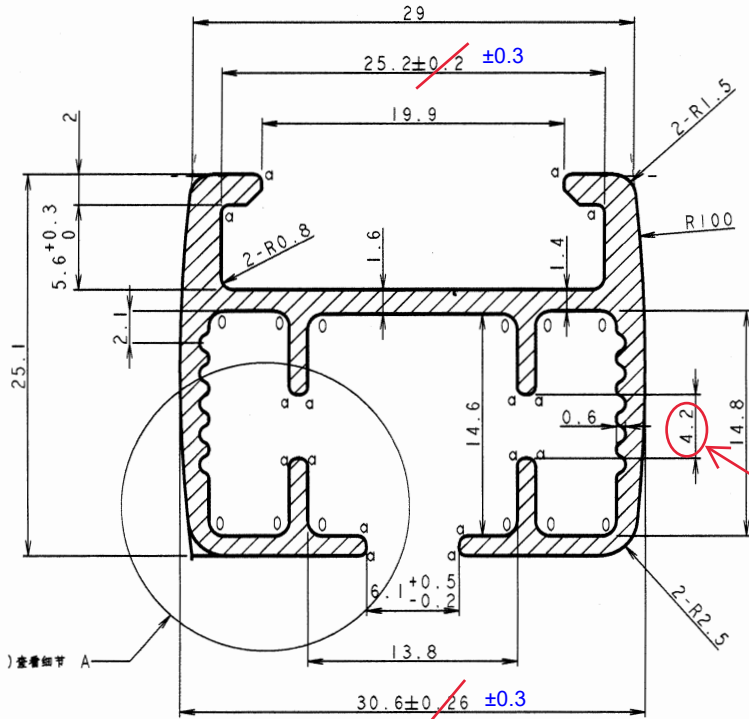

(See Detail) 查看细节 A

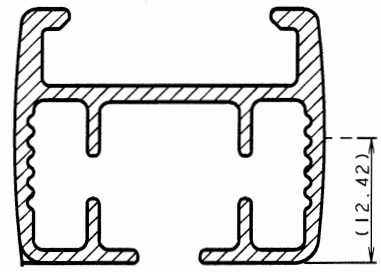

Center of gravity

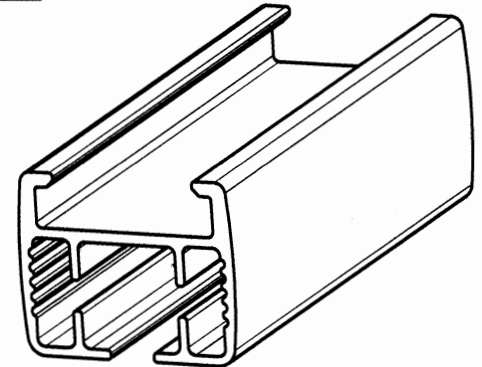

Gap Will be 4.5 mm.

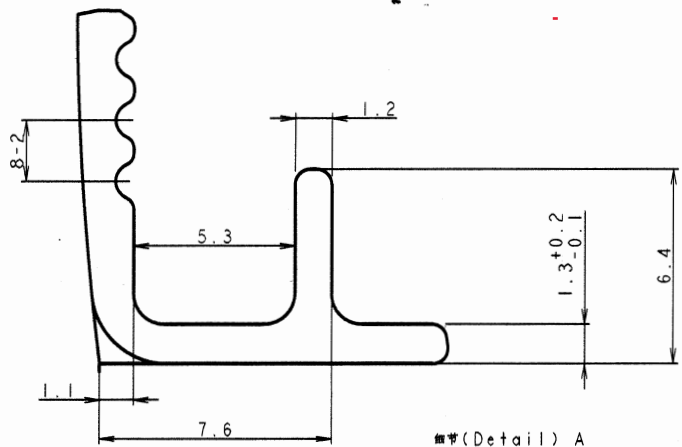

细节 (Detail) A  
比例 (Scale) 6/1

技术要求:

1. 外观无色差、污点等电泳不良。
2.  $\alpha = R0.5, 0 = R1$ , 未注圆角  $R0.3$ 。

Note:

1. Appearance should have no colour aberration, no stain, no lack of painting.
2.  $\alpha = R0.5, 0 = R1$ , other round  $R0.3$ .

No.	BOM	Length	Type(型号)	Remark(备注)
1	5029307A00	4.88m	JXC5059	No catcher mark(切除两端夹具痕迹)
2	5029308A00	6.15m	JXC5059	No catcher mark(切除两端夹具痕迹)

材料 / MATERIAL		联大	
6063-T5		LianDa	
热处理 / HEAT TREATMENT		未注公差 / GENERAL TOLERANCES	
-		0-5 ±0.1 5-10 ±0.2 10-30 ±0.25 30-50 ±0.3 50-120 ±0.45 120-250 ±0.55 250-500 ±0.7 ANGLE ± 1	
A00	change Note and release A version	14/06/19	PB
X03	add technology requirement, add two BOM(for different length)	14/06/17	PB
D6	X02 remove technology requirement	14/06/13	PB
X01	adjust dimensions and tolerances	14/06/12	PB
表面处理 / PROTEC COATING		电镀锌 / Cathode electrophoresis	
X01 adjust dimensions and tolerances		电镀锌 / Cathode electrophoresis	
修改 / MODIFICATION DESCRIPTION		日期 / DATE	姓名 / NAME
修改 / MODIFICATION DESCRIPTION		日期 / DATE	姓名 / NAME

名称 / DESIGNATION:	挤压轨道 / Extrusion Rail	比例 / SCALE:	3/1
		N°:	5028116 A 00