

NOTE:-
All Sharp Corner Radius = 0.50R

LOCATION:-P4-IHOLE
ALL DIMENSION ARE IN mm.
UNSPECIFIED CORNER RADIUS:0.40

TOLERANCE ON CUT LENGTH = ± 5 mm

PLEASE SPECIFY THE EXPOSED SURFACE

TOL. AS PER BS EN 755-9:2008
UNLESS SPECIFIED

TWIST = ±1/4°/300 M.M.
FLATNESS = WIDTH X 0.005mm.
STRAIGHTNESS = 1.50 M.M./MTR.
ANGULARITY = ±1.5°

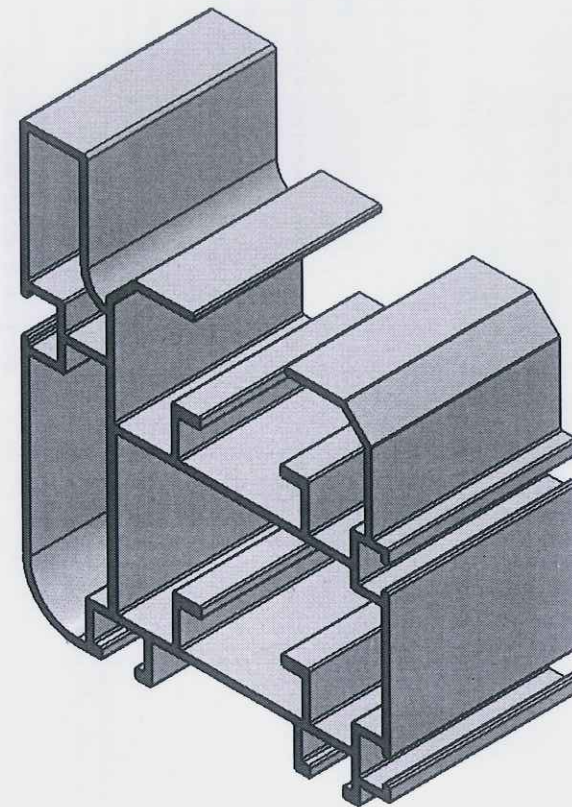

Q02189

INDO ALUSYS INDUSTRIES LIMITED BHIWADI RAJASTHAN - 301019

PARTY SAMPLE & DRG.		SAMPLE	PARTY NAME	M/S TEJ AUTO	REF:- AS PER EMAIL DT.- 16.03.18				
				DRAWN	VIVEK YADAV	17.03.18	AREA	1510.35	MM ²
				CHECKED			WEIGHT	4.078	KG/M.
				APPROVED			WT. RANGE	-----	Kg/12
				SCALE	1:1	DATE	ALLOY	6063-T6	
OO	(REF.)			CRITICAL DIM. *			MAL NO	17033	
REV. STATUS	REV. NO.	DESCRIPTION	SIGN DATE	PERIMETER	INT.	602.56	SEC.NO.	D-7154	
A3		REVISION			EXT.	819.58			