

SCALE: - 1:1

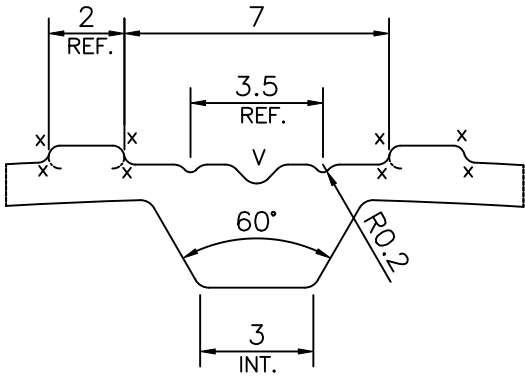

DETAIL OF "A"  
SCALE 5:1

V = VEE GROOVE 0.5x90° (2 PLACES)  
X = RADIUS 0.3 mm. (16 PLACES)

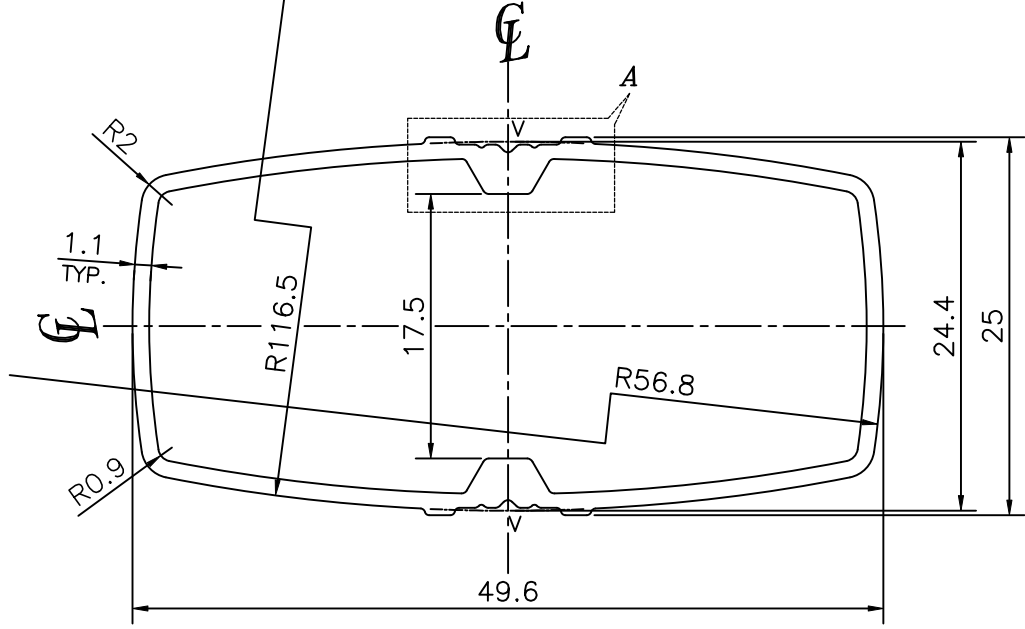

SYMBOL OF QUALITY  
AN ISO 9001 COMPANY

**JINDAL ALUMINIUM LTD.**

BHIWADI-301019

|          | NAME     | DATE       |
|----------|----------|------------|
| DRAWN    | ASHUTOSH | 07-01-2023 |
| CHECKED  |          |            |
| APPROVED |          |            |

1. ALL DIMENSIONS ARE IN mm.
2. ROUND OFF ALL SHARP CORNERS WITH 0.40 mm.
3. TOLERANCES WILL BE AS PER BS: EN-755-9 , UNLESS OTHERWISE SPECIFIED

|                      |        |
|----------------------|--------|
| SCALE                | 2:1    |
| AREA mm <sup>2</sup> | 163.53 |
| PERIMETER mm.        | 137.15 |
| WEIGHT kg/m          | 0.442  |

| PARTY'S NAME        | —                       | DRAWING No. | SECTION No. |
|---------------------|-------------------------|-------------|-------------|
| PARTY'S DRAWING No. | —                       |             |             |
| ALLOY & TEMPER      | HE9 WP                  |             |             |
| DESCRIPTION         | VENETIAN BLINDS SECTION |             |             |