

Model RABP625_REX65_AL_BODY_PROFILE.PART
 Drawing RABP625_REX65_AL_BODY_PROFILE.drw
 ALL DIM. IN MM
 A,B,C,E,H Profile dimension as per EN755-9 Group - I
 Tolerance EN 755-9 Group-I

| ID | Description | Date | By | Appr. |
|----|-------------|------|----|-------|
| | | | | |
| | | | | |
| | | | | |

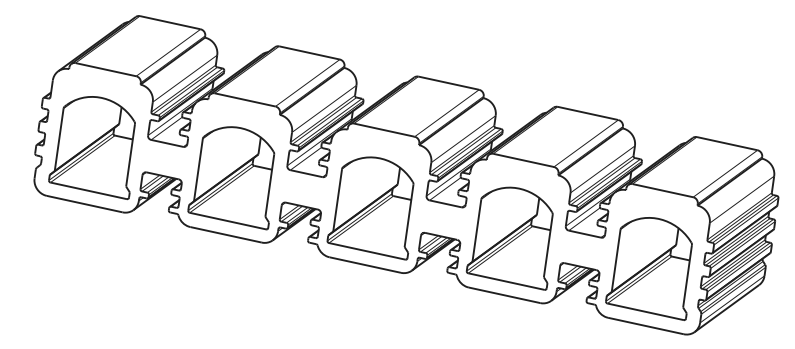
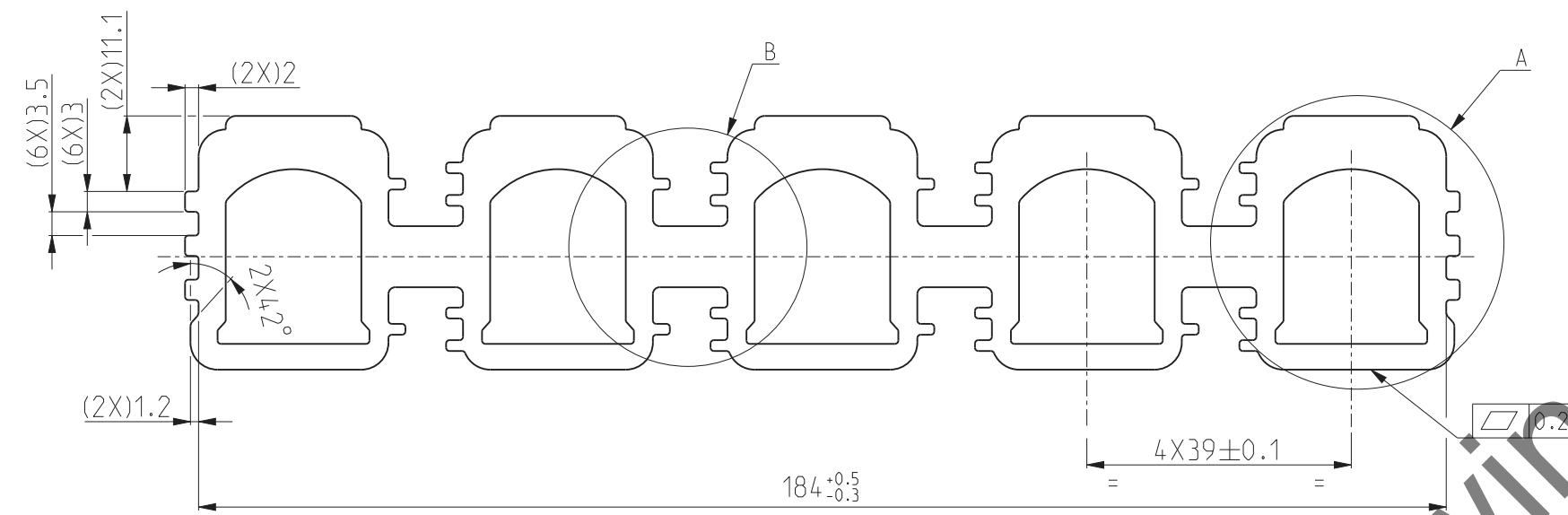

GENERAL VIEW
1:2

Thickness will be 2mm

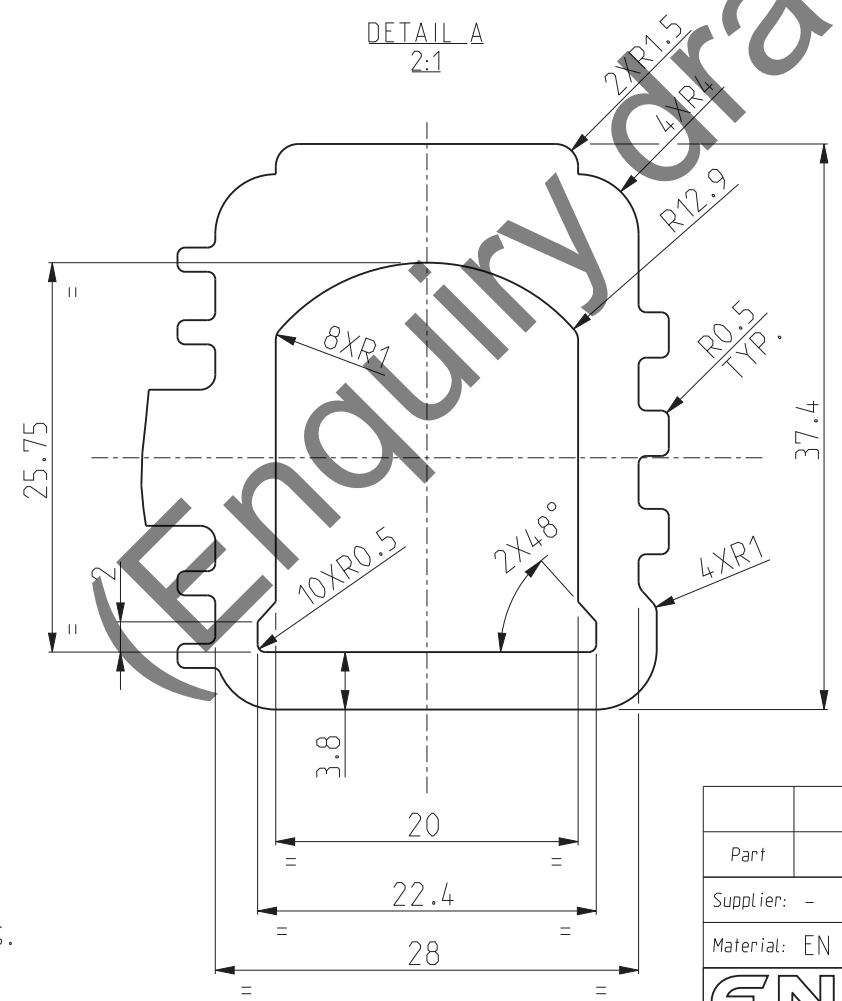
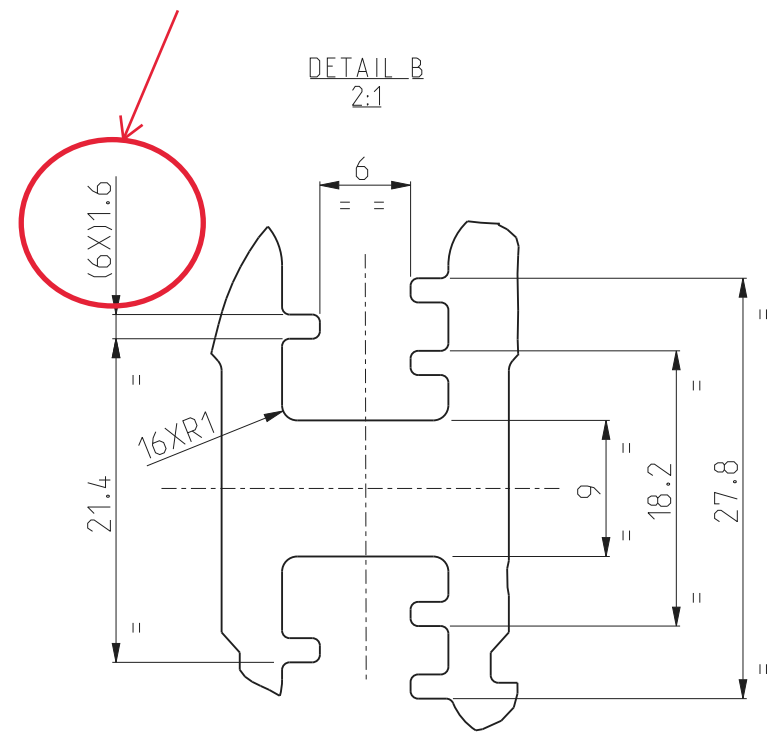

**ALLOY TEMPER-
6005 T6**

- NOTES:-
1. THERE SHOULD NOT BE ANY BURRS, SCRATCHES, FLASHES.
 2. HARDNESS - 85 HB MINIMUM.
 3. HEAT TREATMENT - T6.
 4. AREA -2482mm².
 5. LENGTH -2 METER (MAY VARY).
 6. UNSPECIFIED RADIUS TO BE 0.2mm,FLATNESS 0.2,STRAIGHTNESS 0.2
 7. MARKING DIMENSIONS ARE IMPORTANT, TO BE INSPECTED AND INSPECTION REPORT TO BE SUBMITTED FOR EACH LOT.
 8. THE MATERIAL(ALLOY) SHOULD BE RoHS & REACH COMPLIANCE(RoHS 3).
Lead 0.1% max, Cadmium0.01% max.

| Part | Code | Description | Pcs | Weight (g/pcs) |
|--|---------------|---------------------------------|----------|----------------|
| Supplier: - | | Tool No: - | Volume - | Weight (g) |
| Material: EN AW -6005A T6 | | Ensto Mat: - | | |
| ENSTO ENSTO INDIA PVT. LTD. Ensto DSO | | ALUMINIUM BODY PROFILE REX65 | | |
| Scale 1:1 | Date 26.09.23 | Ref. Drg. No. Replaced: | | |
| A3 | By RKu | Drw No: 000632848 A | | |
| | Checked SS | Ref: REX65 | | |
| Sheet No: 1 (1) | Ctrl RKy | Code: RABP625 | | |