

Model RABP625_REX65_AL_BODY_PROFILE.PART
 Drawing RABP625_REX65_AL_BODY_PROFILE.drw
 ALL DIMN. IN MM
 A.B.C.E.H Profile dimension as per EN755-9 Group - I
 Tolerance EN 755-9 Group-I

ID	Description	Date	By	Appr.

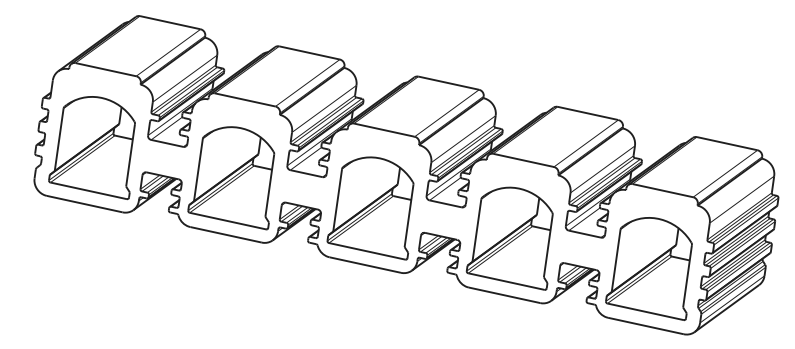

GENERAL VIEW
1:2

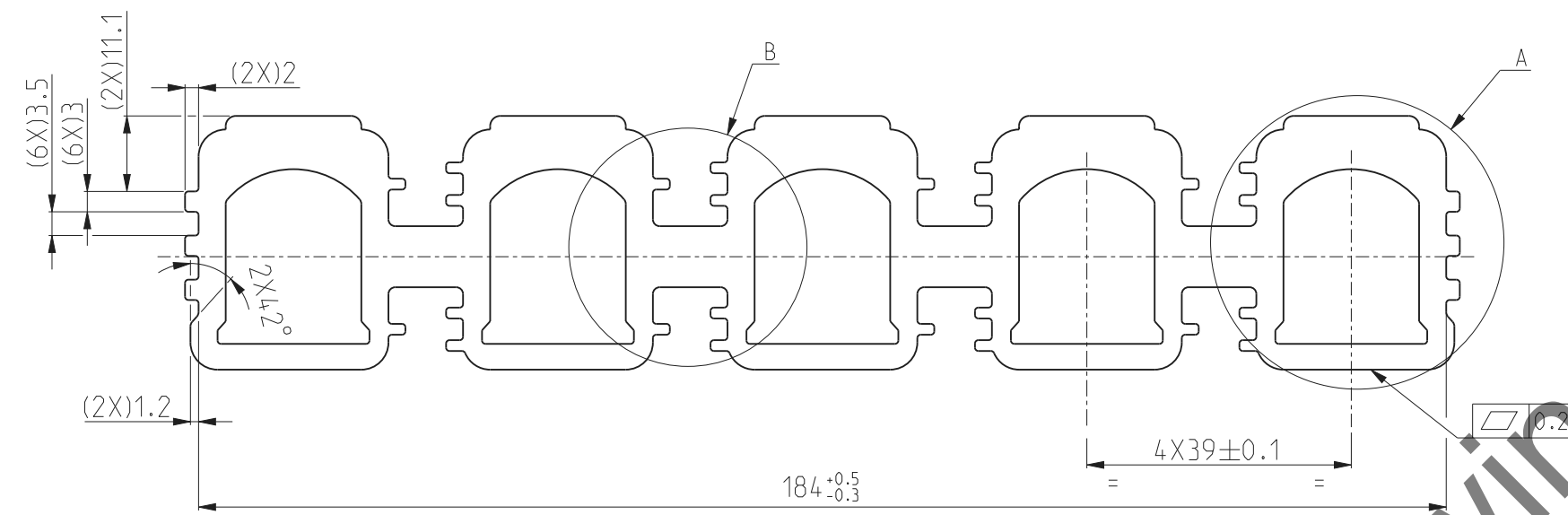
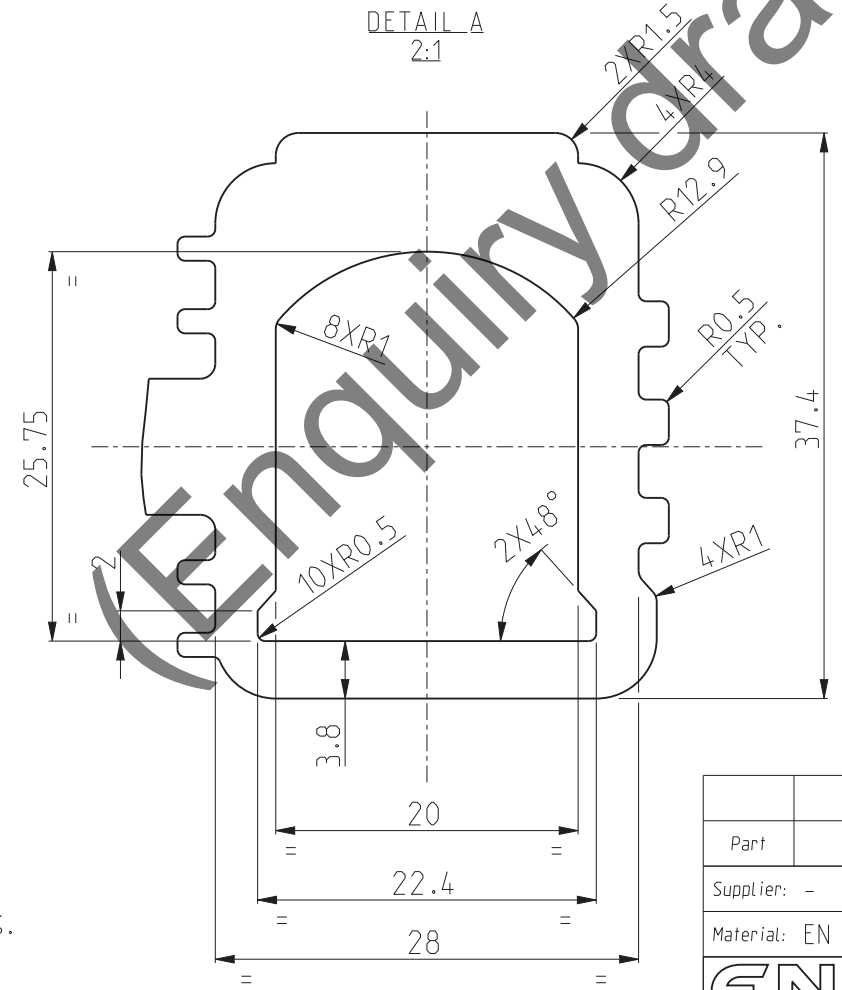
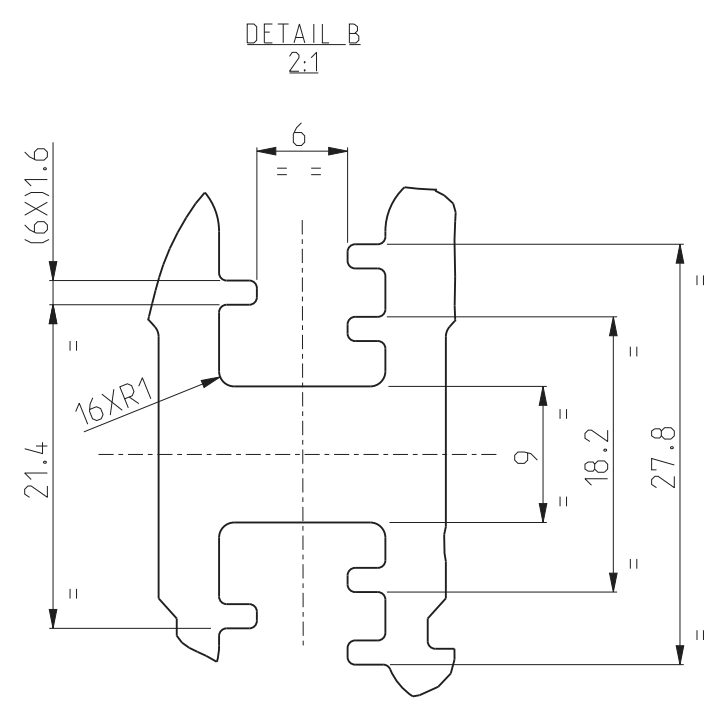

- NOTES:-
1. THERE SHOULD NOT BE ANY BURRS, SCRATCHES, FLASHES.
 2. HARDNESS - 85 HB MINIMUM.
 3. HEAT TREATMENT - T6.
 4. AREA - 2482mm².
 5. LENGTH - 2 METER (MAY VARY).
 6. UNSPECIFIED RADIUS TO BE 0.2mm, FLATNESS 0.2, STRAIGHTNESS 0.2
 7. MARKING DIMENSIONS ARE IMPORTANT, TO BE INSPECTED AND INSPECTION REPORT TO BE SUBMITTED FOR EACH LOT.
 8. THE MATERIAL(ALLOY) SHOULD BE RoHS & REACH COMPLIANCE(RoHS 3).
Lead 0.1% max, Cadmium 0.01% max.

Part	Code	Description	Pcs	Weight (g/pcs)
Supplier: -	Tool No: -	Volume -	Weight (g)	
Material: EN AW -6005A T6		Ensto Mat: -		
ENSTO ENSTO INDIA PVT. LTD. Ensto DSO		ALUMINIUM BODY PROFILE REX65		
Scale 1:1	Date 26.09.23	Ref. Drg. No. Replaced:		
A3	By RKu	Drw No: 000632848 A		
	Checked SS	Ref: REX65		
Sheet No: 1 (1)	Ctrl RKy	Code: RABP625		