

SECTION. NO. - Drawing for approval

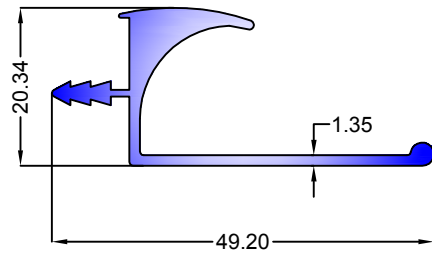

Aprx.Wt.Kg/Mtr - 0.432

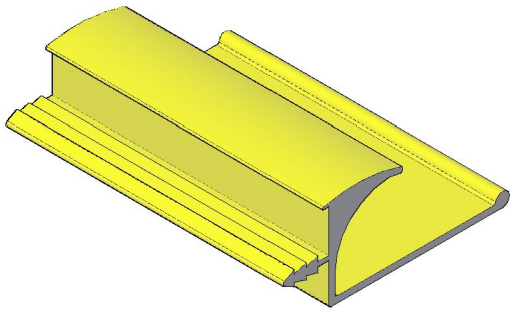
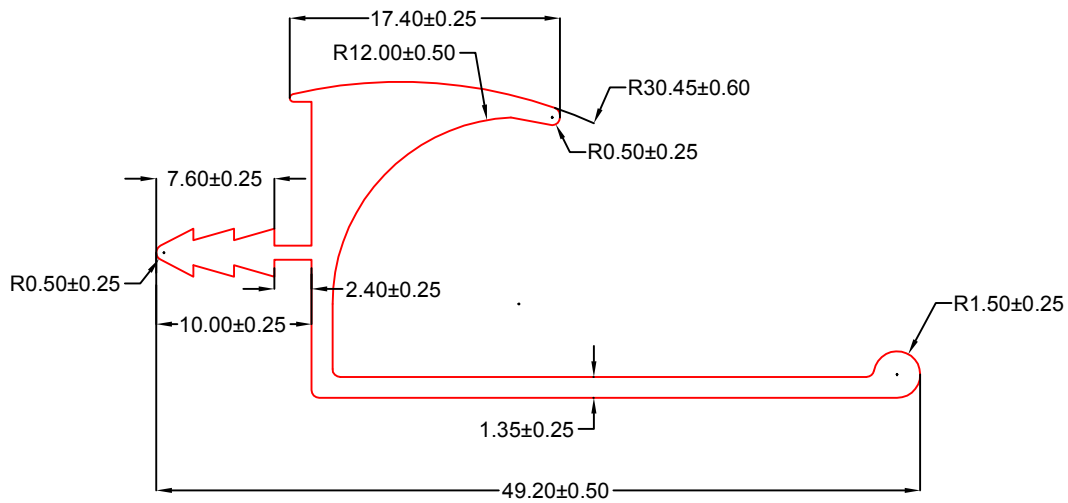

if you have component fittings in section please tell us.

NOTE

FITTING COMPLAINTS WILL NOT BE CONSIDERED

ALL DIMENSION ARE IN M.M.

CRITICAL DIMENSIONS: * MARKS

GENERAL TOLERANCE ±0.30MM

UNSPECIFIED CORNER RADIUS:- 0.30M.M.

TOL, AS PER B.S.1474:1972

UNLESS SPECIFIED

IF NOT PROVIDED BEFORE DIE DEVELOPMENT

TWIST AND BEND =1.70MM/MTR

FLATNESS =0.3 CONCAVE or CONVEX/MTR

ANGULARITY =± 1.5°

PARTY SAMPLE/DRG.NO- DWG	PARTY'S NAME-
DRAWING BY-	END USE -
CHECKED BY-	AREA- 159.953 mm ²
APPROVED BY-	WT.Kgs/Mtr - 0.432
SCALE USED- 1:1	WEIGHT RANGE/MTR -
CRITICAL DIM IF ANY-	PERIMETER - 170.313
DATE- 14.09.2022	D/F —
REMARKS-ER-	DRG NO-