

GB 5237.1-2017(High Precision)

Size	Tolerance
≤3	±0.13
>3-10	±0.15
>10-15	±0.17
>15-30	±0.21
>30-45	±0.26
>45-60	±0.31
>60-100	±0.52

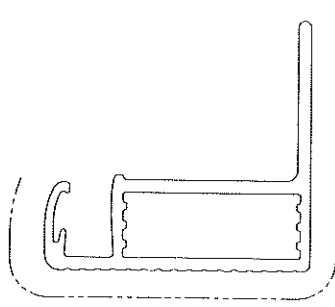

1:1

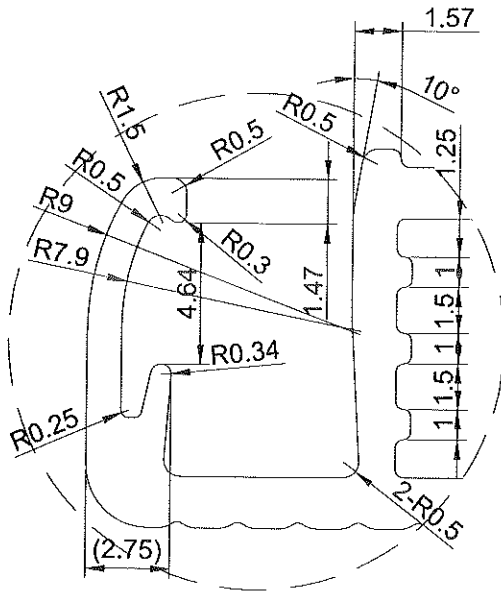
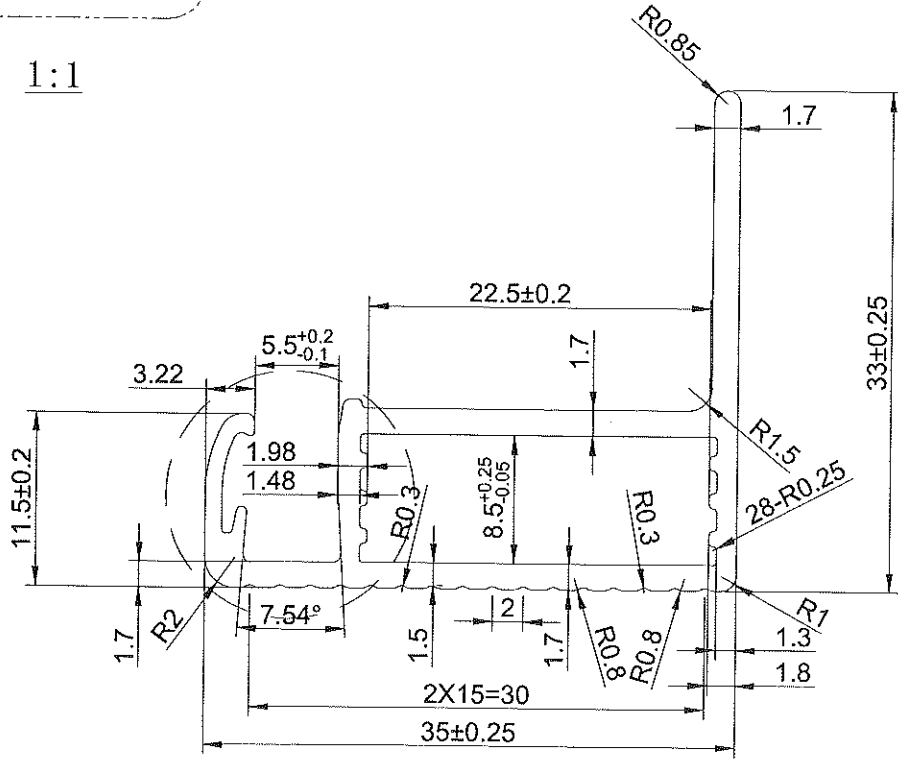

002328

A
4:1

Technical Requirements:

- 1.UNSPEC Thickness:±0.13
- 2.Exe Std:GB5237.1-2017 High Precision
- 3.Hardness:≥14HW

Note:

1. Unspec.wall thickness T _____ mm
2. Unspec.corners rounded to R 0.2 mm
3. _____ is exposed surface.
4. Perimeter _____ 159.499 mm
5. Section area _____ 180.164 mm²
6. Liner density _____ 0.488 kg/m
7. Circumcircle _____ Φ47 mm

Machine		Processed		Change		Drawing Number	YR498	NO.		
Client		Checked		Date				Scale	2:1	
Date		Released		Name		Discription	35X33 Frame	Revision	A/0	
Jiangyin HaiHong New Energy Technology Co., LTD								Material	6005T6	Page
									Total	