

1:1

GB 5237.1-2017(High Precision)	
Size	Tolerance
≤3	±0.13
>3-10	±0.15
>10-15	±0.17
>15-30	±0.21
>30-45	±0.26
>45-60	±0.31
>60-100	±0.52

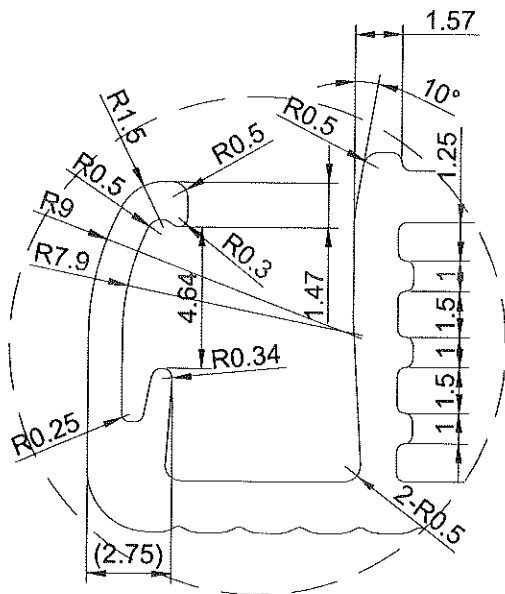
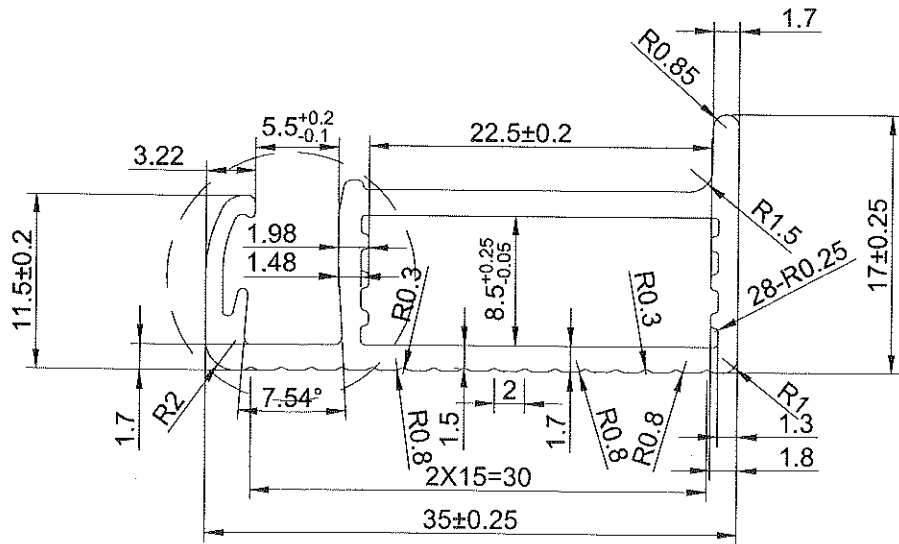

Q02339

A
4:1

Technical Requirements:
 1. UNSPEC Thickness: ±0.13
 2. Exe Std: GB5237.1-2017 High Precision
 3. Hardness: ≥14HW

Note:

- Unspec. wall thickness T _____ mm
- Unspec. corners rounded to R 0.2 mm
- _____ is exposed surface.
- Perimeter 127.499 mm
- Section area 152.964 mm²
- Liner density 0.415 kg/m
- Circumcircle Ø38 mm

Machine		Processed		Change		Drawing Number	YR499	NO.		
Client		Checked		Date				Scale	2:1	
Date		Released		Name		Discription	35X17 Frame	Revision	A/0	
Jiangyin HaiHong New Energy Technology Co., LTD								Material	6005T6	Page
									Total	