

GB 5237.1-2017(High Precision)

Size	Tolerance
≤3	±0.13
>3-10	±0.15
>10-15	±0.17
>15-30	±0.21
>30-45	±0.26
>45-60	±0.31
>60-100	±0.52

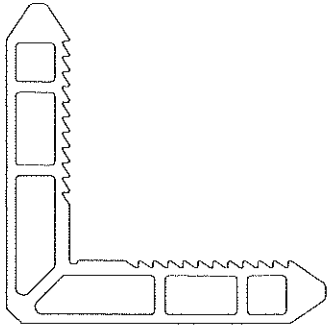

1:1

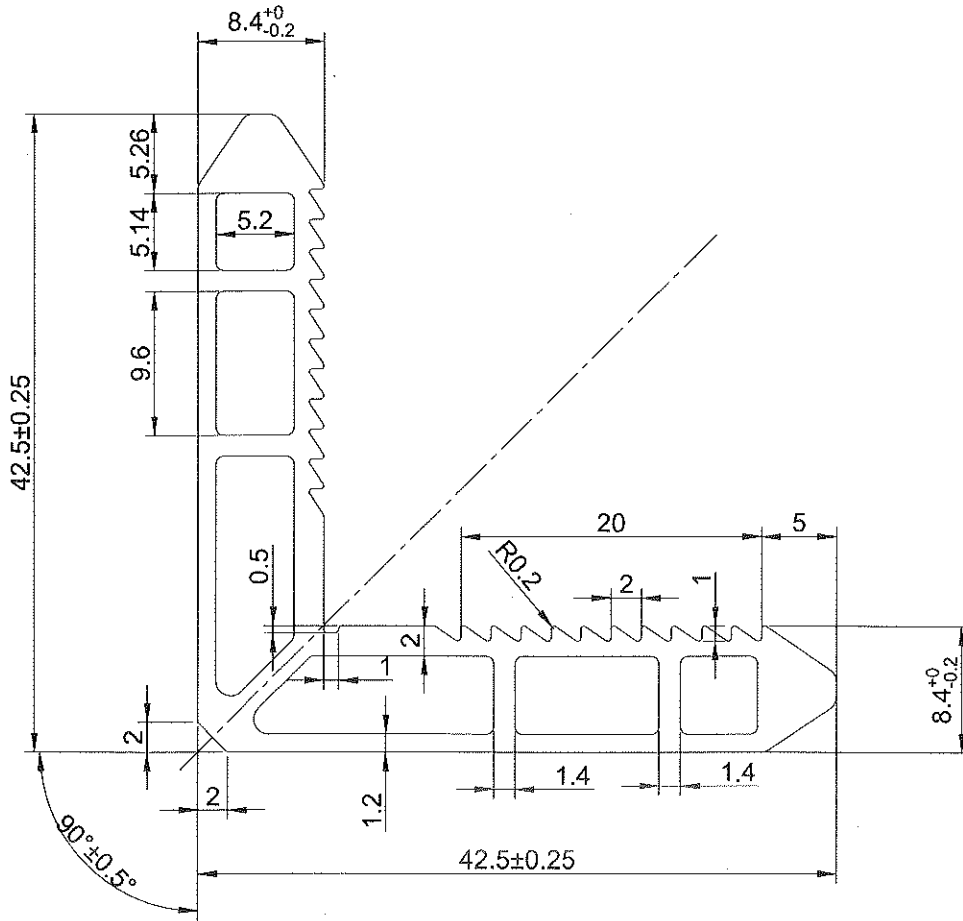

Q02340

Technical Requirements:

1. UNSPEC Thickness: ±0.15
2. Exe Std: GB5237.1-2017 High Precision
3. Hardness: ≥14HW

Note:

1. Unspec. wall thickness T \_\_\_\_\_ mm
2. Unspec. corners rounded to R 0.2 mm
3. \_\_\_\_\_ is exposed surface.
4. Perimeter 184.945 mm
5. Section area 285.184 mm<sup>2</sup>
6. Liner density 0.773 kg/m
7. Circumcircle Φ55 mm

Machine		Processed		Change		Drawing Number	HHTJL42.5-8.4	NO.	
Client		Checked		Date				Scale	2:1
Date		Released		Name		Discription	Angle Joint	Revision	A/0
Jiangyin HaiHong New Energy Technology Co., LTD								Material	6005-T6
									Total