

DETAIL-A
SCALE 4 : 1

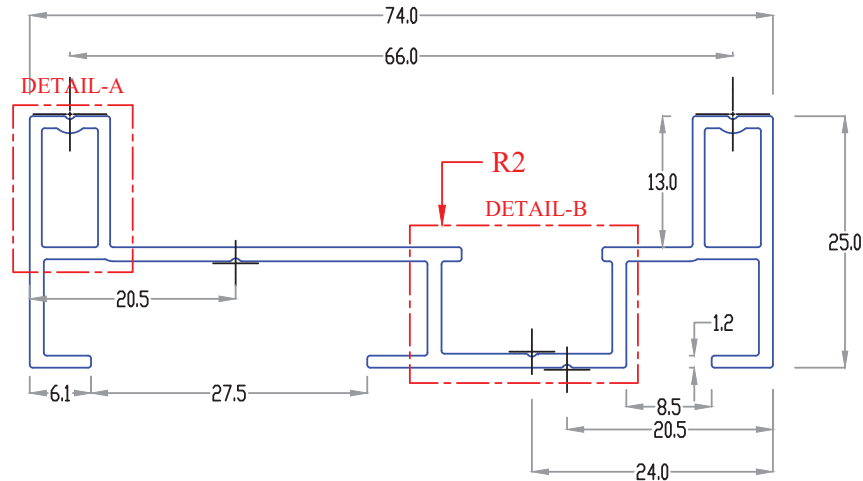

SCALE 2 : 1

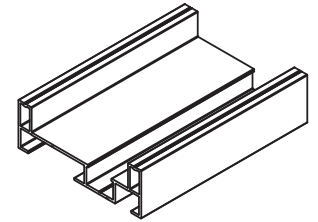

Isometric View

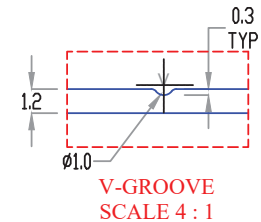

V-GROOVE
SCALE 4 : 1

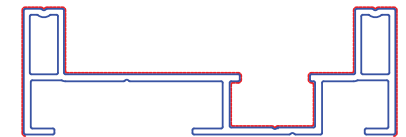

Powder Coated Area

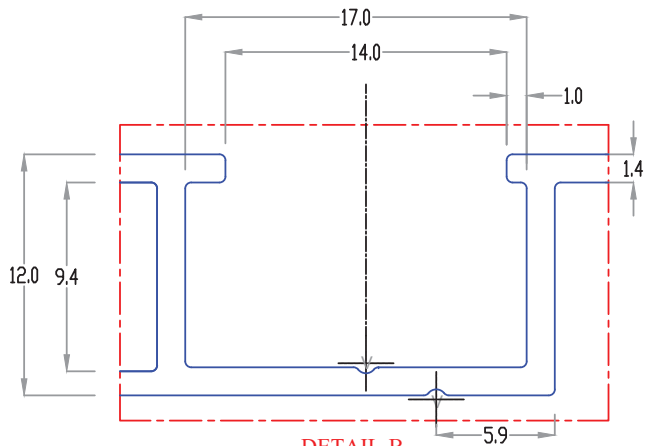

DETAIL-B
SCALE 4 : 1

Surface Area (mm ²)	Weight (Kg/m)	Total Area (m ²)	Powder Coated Area (m ²)
259.9751	0.702	0.322	0.176
MATERIAL ALUMINIUM 6063 T6			
DENSITY 2700 kg/m ³			
UNSPECIFIED CORNER RAD. 0.3mm			
STRAIGHTNESS As per EN12020 : (±3mm, 5m<L<6m)			
ANGULARITY ± 1° (EN12020)			
FLATNESS TOL. ±0.8mm			
TWIST TOL. 1.0mm/m (EN12020)			
SIGNIFICANT CHARACTERISTICS			
SURFACE FINISH: POWDER COATING (60 to 80µm Thk.)			
FINISH AREA: 0.364(m ²)			
SCALE 1:1	Description:- 3T SIDE FRAME-1 (PR 25X74_SIDE_2T4P MF AL AS23PF23)		
Format A3	Drawing No :- AS23PF23		

V - GROOVE
REF - REFERENCE DIMENSION
TYP - TYPICAL DIMENSION

Notes:-

- A. Extrusion :
 - a. Part must be clean and free from tool marks.
 - b. No Waviness, Pitting, Bending acceptable on part.
 - c. Parts must be free from internal cracks.
- B. Part must be free from powder coating defect like Pitting, Blow holes, inclusion etc.
- C. Part must be same as engineering approved sample.

FOR CONSULTATION ONLY

REV.	Date	Prepared by:	Approved By:	Description
R2	08/01/2024	RITESH SRIVASTAVA	VIVEK GUPTA	DETAIL-B CHANGED

All dimension are in mm.

Unspecified general tol: EN 12020-2			
From 0 mm to 10 mm	± 0.15mm	From 45 mm to 60 mm	± 0.40
From 10 mm to 15 mm	± 0.20mm	From 60 mm to 90 mm	± 0.45
From 15 mm to 30 mm	± 0.25mm	From 90 mm to 120 mm	± 0.60
From 30 mm to 45 mm	± 0.30mm	From 120 mm to 150 mm	± 0.80

CONFIDENTIAL - EXCLUSIVE PROPERTY OF FENESTA BUILDING SYSTEM

DATE	FENESTA BUILDING SYSTEMS		Sheet
27-11-2023			1 of 1
Prepared by:	Checked by:	1st Approver:	2nd Approver:
RITESH SRIVASTAVA	VIVEK GUPTA	Y.P SINGH	R2