

P-JAL-B-760

Q02430

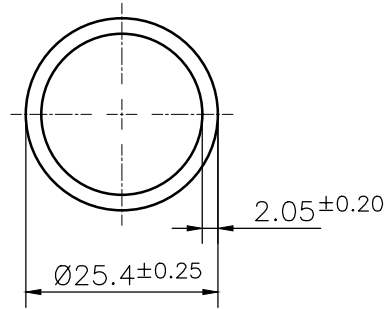

☞ *NO DENT, BURR ROLLING MARK,
APPEARANCE DEFECTS ALLOWED*

1. STRAIGHTNESS= 1.7mm/M
2. TWIST= 1.7mm/M
3. ANGULARITY= $\pm 2^\circ$
4. FLATNESS= 0.007xWIDTH

Q02073

UNCONTROLLED COPY

1) THE WELDING LINE IN THE EXPOSED SURFACE OF PROFILE IS UNAVOIDABLE. 2) PLEASE SPECIFY IMPORTANT SIZES. 3) PLEASE SPECIFY IF THIS PROFILE MATCHES WITH OTHER PROFILES. 4) PLEASE SPECIFY EXPOSED SURFACE. OTHER WISE CONSIDERED AS NO EXPOSED SURFACE. 5) FINISH :- MILL FINISH / ANODIZING / POWDER COATING

 SYMBOL OF QUALITY AN ISO 9001 COMPANY	JINDAL ALUMINIUM LTD. <i>BHIWADI-301019 (INDIA)</i>		NAME	DATE
			DRAWN	ASHUTOSH
1. ALL DIMENSIONS ARE IN mm. 2. ROUND OFF ALL SHARP CORNERS WITH 0.40 mm. 3. TOLERANCES WILL BE AS PER BS:EN-755-9 , UNLESS OTHERWISE SPECIFIED			CHECKED	
			APPROVED	
PARTY'S NAME FORZA MEDI (I) PVT. LTD.			SCALE	1:1
			AREA mm ²	150.38
PARTY'S DRAWING No. AS PER DRAWING-FMI-C-0284			PERIMETER mm.	79.796
			WEIGHT kg/m	0.406
ALLOY & TEMPER 6005 T6			DRAWING No.	SECTION No.
			P-JAL-B-760	-
DESCRIPTION ROUND TUBE			-	-
PRODUCT CODE:-006 HSN CODE:- 76082000				