

WHERE USED
PWB600

CTQ CHECK POINTS

CHG.NO.	REV	REVISION	DRAWN	DATE

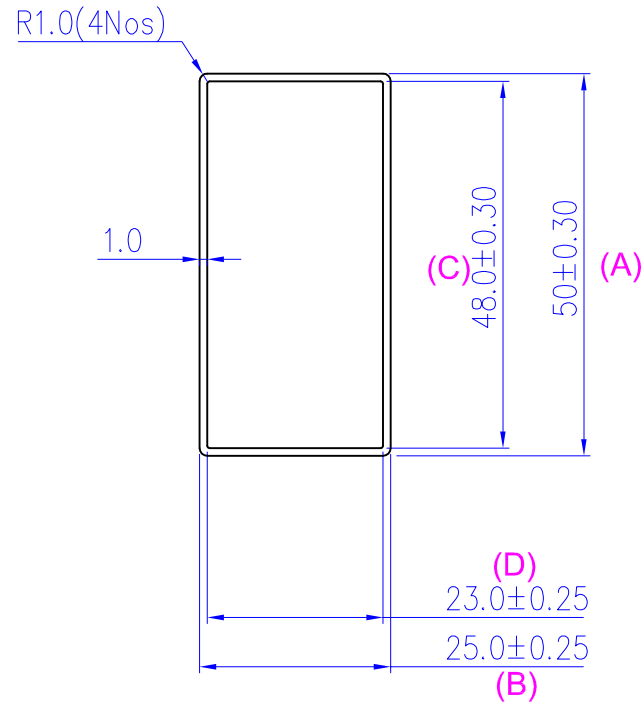

INCOMING INSPECTION:-

- (A) DIM. = 49.70 TO 50.30 - V.C
- (B) DIM. = 24.75 TO 25.25 - V.C
- (C) DIM. = 47.70 TO 48.30 - V.C
- (D) DIM. = 22.75 TO 23.25 - V.C
- (E) NO ANODIZING DEFECTS. - VISUAL

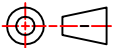
MAT'L: Aluminium 6063T6	SCALE: - NTS	DATE:	 <b style="font-size: 24px;">CSTech <small>COMPLETE SURVEYING TECHNOLOGIES</small>	
FINISH: - Anodized	DRN. BY: - Aman	11/10/10		
TOLERANCES UNLESS OTHERWISE SPECIFIED. .X = ±0.2mm .XX = ±0.1mm .XXX = ±0.05mm ANGULAR = ±1° NOTE: - BREAK ALL SHARP CORNERS.	CKD. BY:-			
	APD. BY:-			
PART NAME: - 0030 Upright Extrusion LH 50x25mm				
UNITS: MM		CODE: - PWB	DRAWING NO. PWB - 0030/E	REV D