

P-JAL-B-440

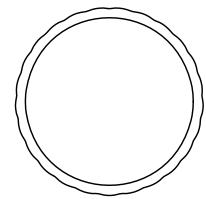

SCALE 1:1

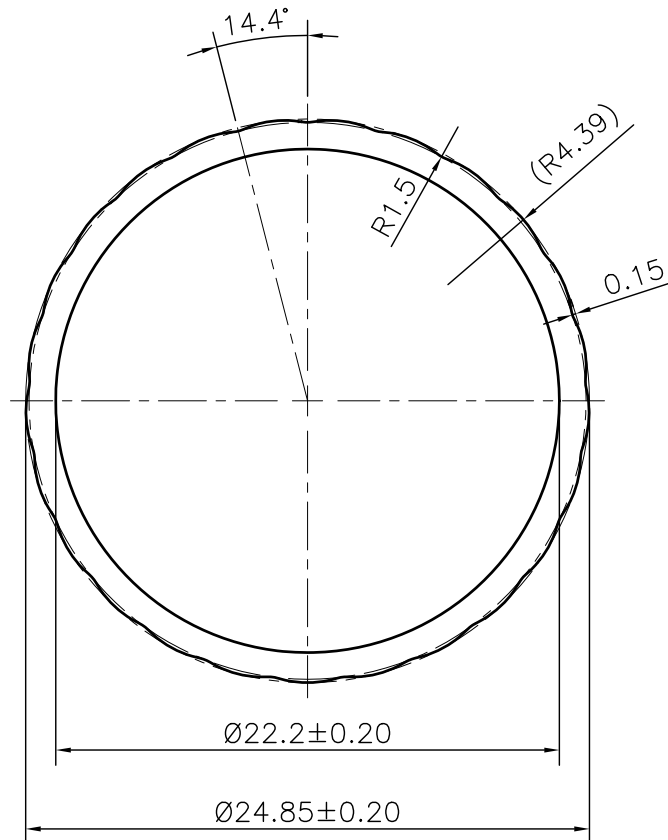

25 FLUTES

- 1. STRAIGHTNESS= 1.7mm/M
- 2. TWIST= 1.7mm/M
- 3. ANGULARITY= ±2°
- 4. FLATNESS= 0.007xWIDTH

UNCONTROLLED COPY

1) THE WELDING LINE IN THE EXPOSED SURFACE OF PROFILE IS UNAVOIDABLE. 2) PLEASE SPECIFY IMPORTANT SIZES. 3) PLEASE SPECIFY IF THIS PROFILE MATCHES WITH OTHER PROFILES. 4) PLEASE SPECIFY EXPOSED SURFACE. OTHER WISE CONSIDERED AS NO EXPOSED SURFACE. 5) FINISH :-  MILL FINISH /  ANODIZING /  POWDER COATING

 SYMBOL OF QUALITY AN ISO 9001 COMPANY	<b>JINDAL ALUMINIUM LTD.</b> BHIWADI-301019 (INDIA)		NAME	DATE
			DRAWN	ASHUTOSH 01-02-2024
		CHECKED		
		APPROVED		
1. ALL DIMENSIONS ARE IN mm. 2. ROUND OFF ALL SHARP CORNERS WITH 0.40 mm. 3. TOLERANCES WILL BE AS PER BS:EN-755-9 , UNLESS OTHERWISE SPECIFIED		SCALE		3:1
		AREA mm <sup>2</sup>	93.393	
		PERIMETER mm.	78.184	
		WEIGHT kg/m	0.252	
PARTY'S NAME	UNGER INDIA PVT. LTD., GURGAON		DRAWING No.	SECTION No.
PARTY'S DRAWING No.	AS PER SAMPLE		P-JAL-B-440	-
ALLOY & TEMPER	6063 T6	PRODUCT CODE:-011	-	-
		HSN CODE:- 76042100		
DESCRIPTION	FLUTED ROUND TUBE			