

SECTION B-B
SCALE 1.5 : 1

GENERAL NOTE:
1- TOLERANCE FOR EXTRUSION;
X.X mm ... ±0.30 mm
X.XX mm... ±0.20 mm

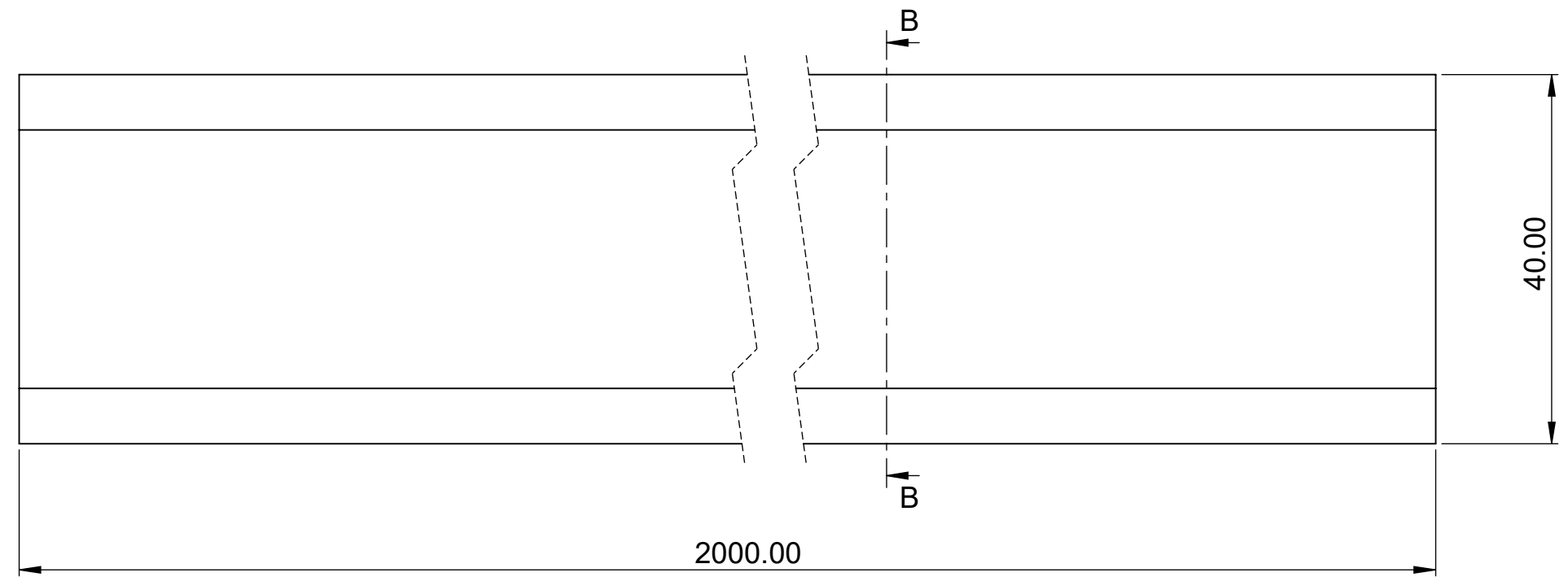
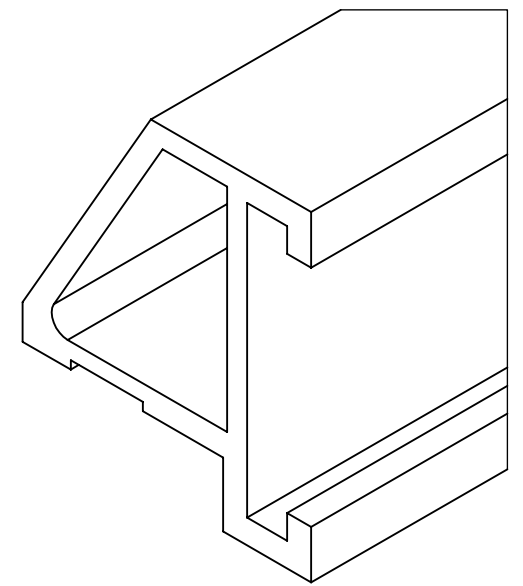

Resistoflex

Email: sourcing@resistoflex.in

PROJECTION REPORT ALL ERRORS & CHANGES

REMOVE ALL BURRS AND SHARP EDGES

GENERAL TOLERANCES:

CASTING:.....±.76 mm MACHINING { .XX...±.13 mm
FABRICATION... ±.51 mm .x.....±.38 mm
SURFACE TAXTURE...3.2 µm ANGULAR.....0°30'

Drwn: RK	16.03.2024	ALL DIMENSIONS ARE IN MM
Chkd: MJ		
Appd: AJ		SCALE: NTS

**NON CONTROLLED COPY
FOR REFERENCE ONLY**

MATERIAL: AL-6063-T6

STANDARD: EN 573-3 & EN 755-2

TITLE: ALUMINIUM EXTRUSION FOR FRAME	APPROX Wt.(Kg.) --
--	--------------------------

DRG. NO.: RIC-R090-005-001	REV 00
--------------------------------------	------------------

REF:	
STRICTLY CONFIDENTIAL- DO NOT COPY, DO NOT DISCLOSE TO THIRD PARTIES. This document contains industrial secrets. This drawing is the property of RESISTOFLEX, it must not be reproduced or communicated without authorization, and returned after use.	SHEET 1/1