

UNCONTROLLED COPY
NOT FOR PRODUCTION
UNLESS OVERSTAMPED
"CONTROLLED"
IN RED INK

BY	DATE	ALTERATIONS	ISSUE
CVA	07/03/2017	PRODUCTION RELEASE PR17-017	A
-	-	-	-
-	-	-	-
-	-	-	-

Q01537-PROPOSAL DRAWING

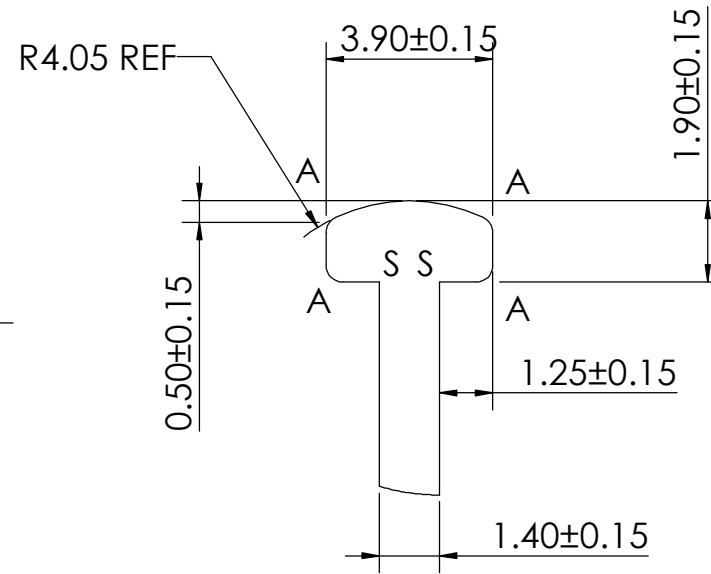
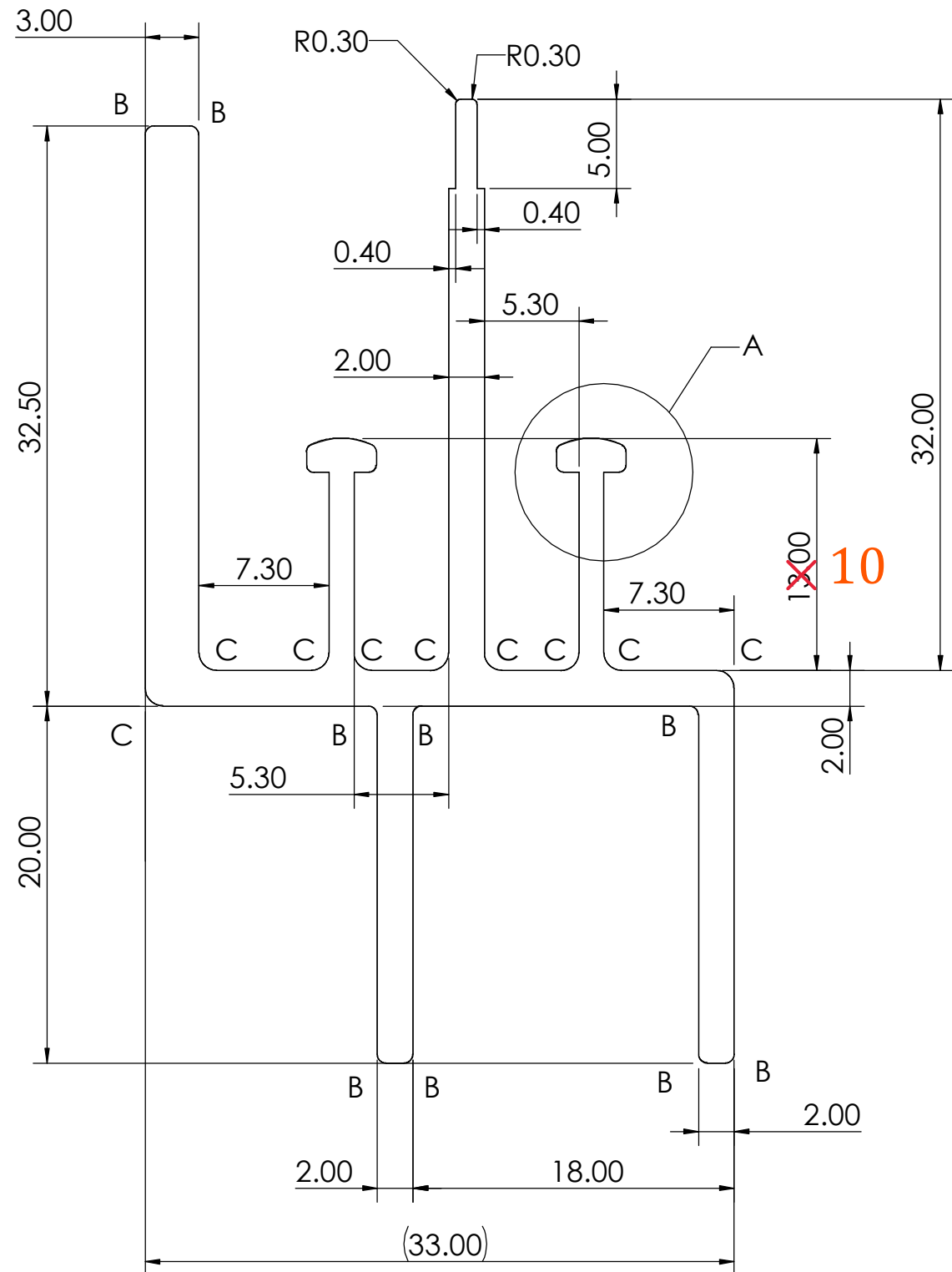

DETAIL A
TYPICAL 2 PLS
SCALE 8 : 1

COMPONENT INFORMATION

1. AREA - 342.83 mm²
2. MATERIAL - ALUMINIUM ALLOY TO BS EN755 6063T6
3. ESTIMATED WEIGHT - 0.9291 KG/M

A - DENOTES 0.4 RAD
B - DENOTES 0.5 RAD
C - DENOTES 1.0 RAD
S - DENOTES SHARP CORNER
ALL UNSPECIFIED RADS 0.2

————— DENOTES VISIBLE SURFACE
- - - - - DENOTES HIDDEN SURFACE

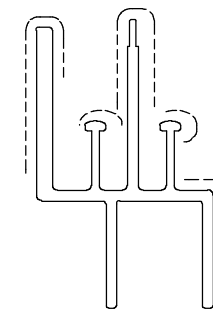

SCALE 1:1

DESIGNER	CVA 04/01/2017
TOLERANCES UNLESS OTHERWISE SPECIFIED	
X	±
X.X	±
X.XX	±
HOLE CRS	±
ANGULAR	± 0.5°
MATERIAL	SEE NOTES
FINISH	SEE NOTES
WEIGHT 18.51	CE No. CE16-032
Widney	
TITLE CROSSRAIL SECTION	
PART No 29/64767	SHT 1 OF 1 ISSUE A

