

REMOVE ALL SHARP CORNERS/EDGES

CAD DRAWING DO NOT MODIFY DO NOT SCALE DRAWING

UNCONTROLLED COPY  
NOT FOR PRODUCTION  
UNLESS OVERSTAMPED  
"CONTROLLED"  
IN RED INK

BY	DATE	ALTERATIONS	ISSUE
CVA	07/03/2017	PRODUCTION RELEASE PR17-017	A
-	-	-	-
-	-	-	-
-	-	-	-

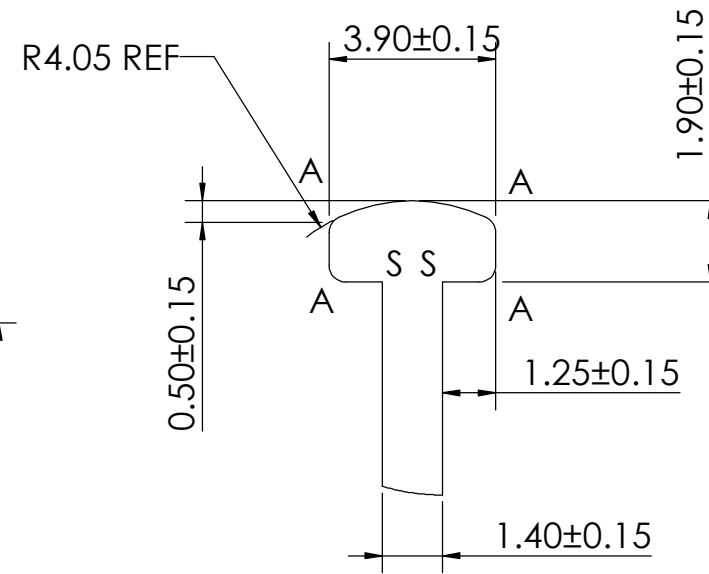
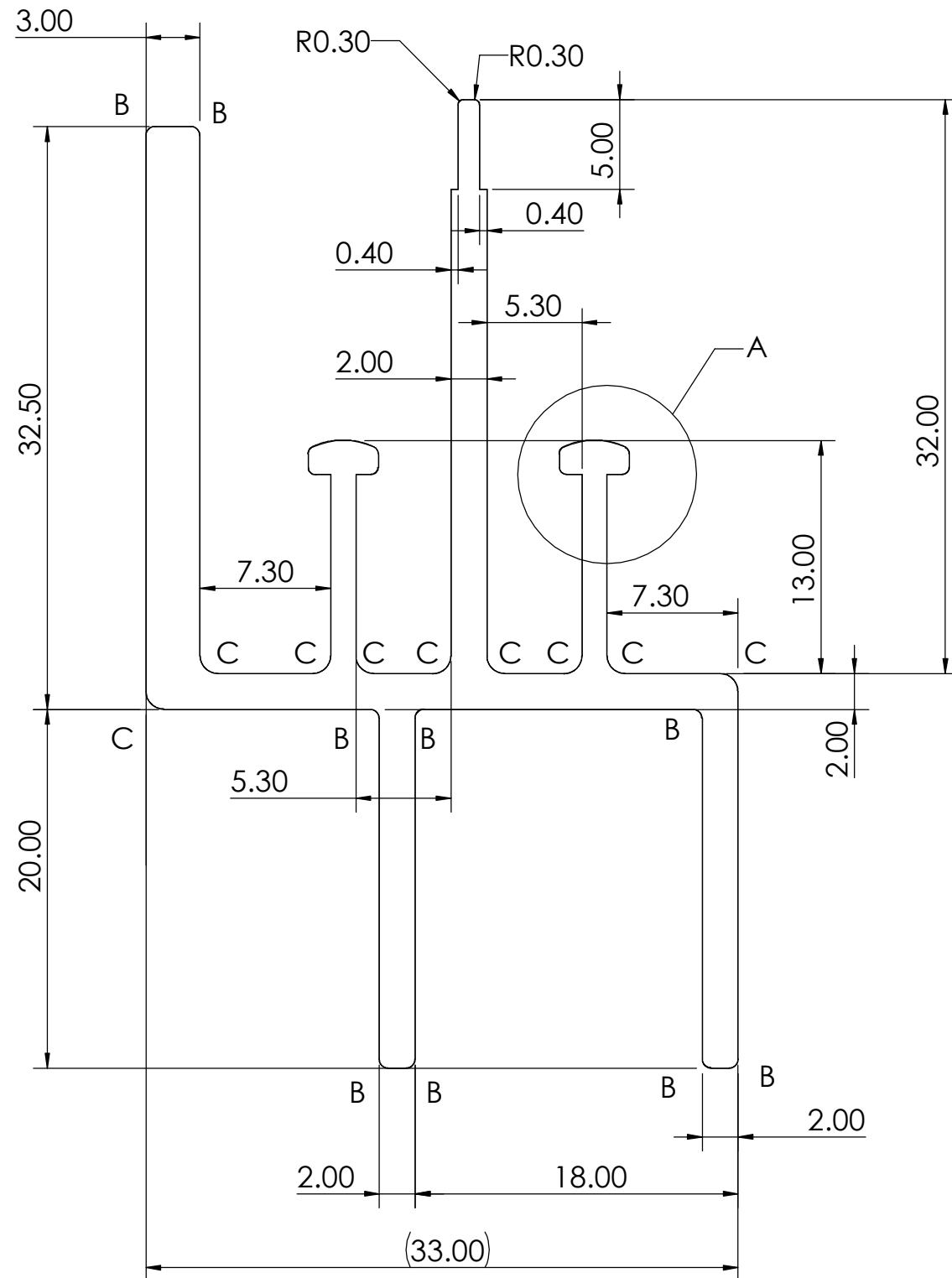

DETAIL A  
TYPICAL 2 PLS  
SCALE 8 : 1

COMPONENT INFORMATION

1. AREA - 342.83 mm<sup>2</sup>
2. MATERIAL - ALUMINIUM ALLOY TO BS EN755 6063T6
3. ESTIMATED WEIGHT - 0.9291 KG/M

A - DENOTES 0.4 RAD  
B - DENOTES 0.5 RAD  
C - DENOTES 1.0 RAD  
S - DENOTES SHARP CORNER  
ALL UNSPECIFIED RADS 0.2

————— DENOTES VISIBLE SURFACE  
- - - - -

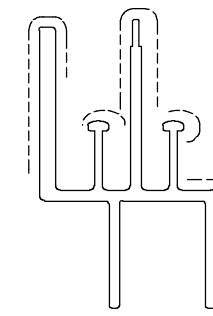

SCALE 1:1

DESIGNER	CVA 04/01/2017
TOLERANCES UNLESS OTHERWISE SPECIFIED	
X	±
X.X	±
X.XX	±
HOLE CRS	±
ANGULAR	± 0.5°
MATERIAL	SEE NOTES
FINISH	SEE NOTES
WEIGHT 18.51	CE No. CE16-032
<b>Widney</b>	
TITLE CROSSRAIL SECTION	
PART No 29/64767	SHT 1 OF 1 ISSUE A

A2

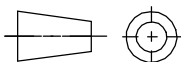

THIRD ANGLE PROJECTION

DIMENSIONS ARE IN MILLIMETRES  
UNLESS OTHERWISE STATED

METRIC SCREW THREADS SHALL CONFORM TO THE  
LIMITS AND TOLERANCES SPECIFIED IN THE CURRENT  
BS3643 PT2 CLASS 6g EXTERNAL OR 6H INTERNAL

© WIDNEY MANUFACTURING LTD THIS DOCUMENT IS CONFIDENTIAL AND THE DOCUMENT AND THE COPYRIGHT THEREIN ARE  
THE PROPERTY OF WIDNEY MANUFACTURING LTD. THE DOCUMENT AND ANY INFORMATION THEREIN MAY NOT BE USED  
COPIED OR DISCLOSED TO ANY THIRD PARTY WITHOUT THE PRIOR WRITTEN AUTHORISATION OF WIDNEY MANUFACTURING LTD