

S450

1905

12047

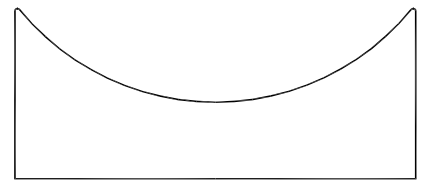
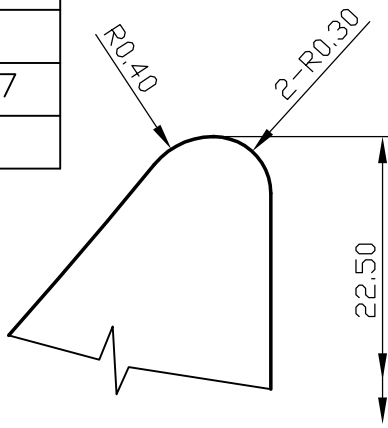

1:1

DETAILS 'A'
SCALE 25:1

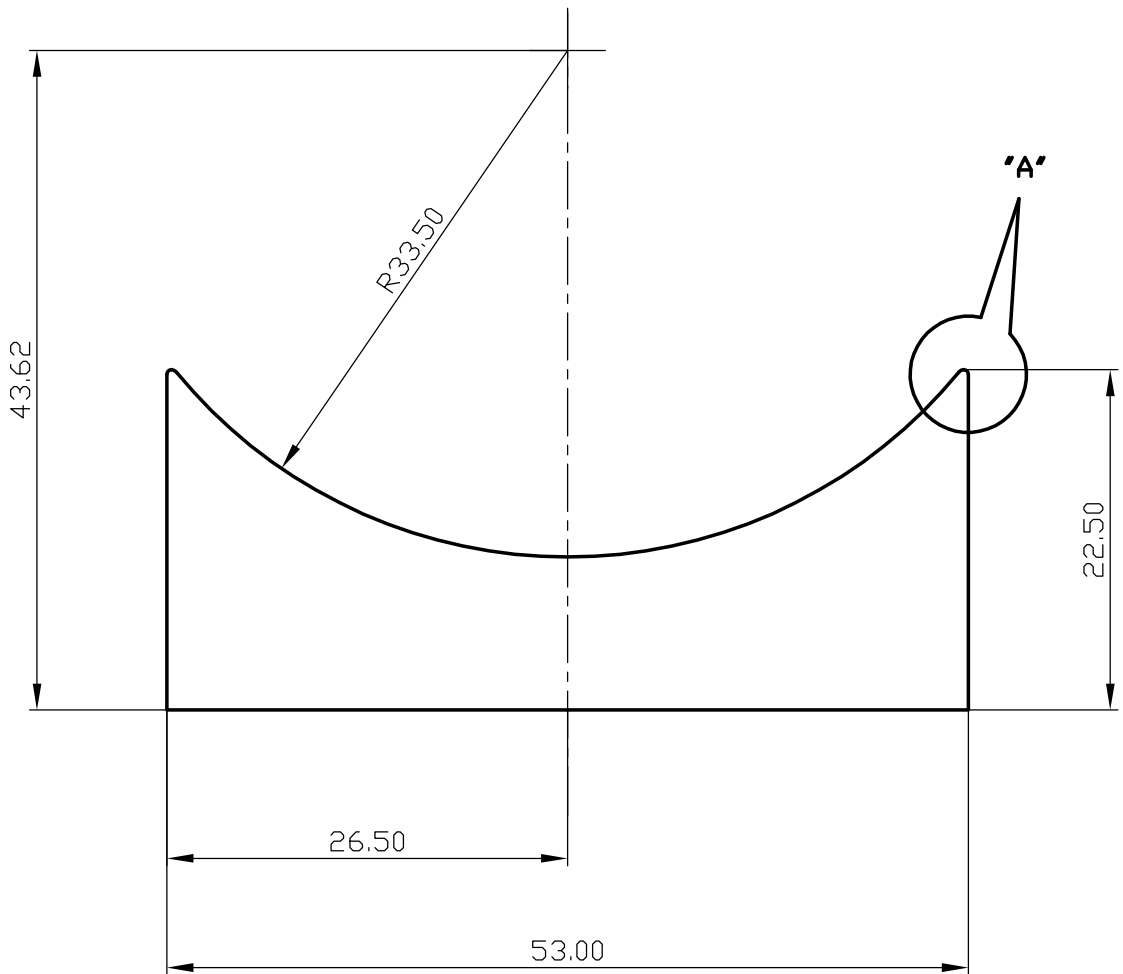

 SYMBOL OF QUALITY AN ISO 9002 COMPANY	JINDAL ALUMINIUM LTD. BANGALORE-560073 (INDIA)		NAME	DATE
			DRAWN	P,KULKARNI 19-1-2000
1. ALL DIMENSIONS ARE IN mm. 2. ROUND OFF ALL SHARP CORNERS WITH 0.40 mm. 3. TOLERANCES WILL BE AS PER IS:3965-1981 UNLESS OTHERWISE SPECIFIED			CHECKED	
			APPROVED	
			SCALE	2:1
PARTY'S NAME	APPASAMY INSTRUMENTS, CHANNAI.		WEIGHT kg/m	2.009
PARTY'S DRAWING No.	AS PER SKETCH		SECTION No.	12047
ALLOY & TEMPER	HE9 WP	LENGTH: 3658 mm	DRAWING No.	
DESCRIPTION	MISC SOLID BAR		12047	