

P-14277

S4329

12296

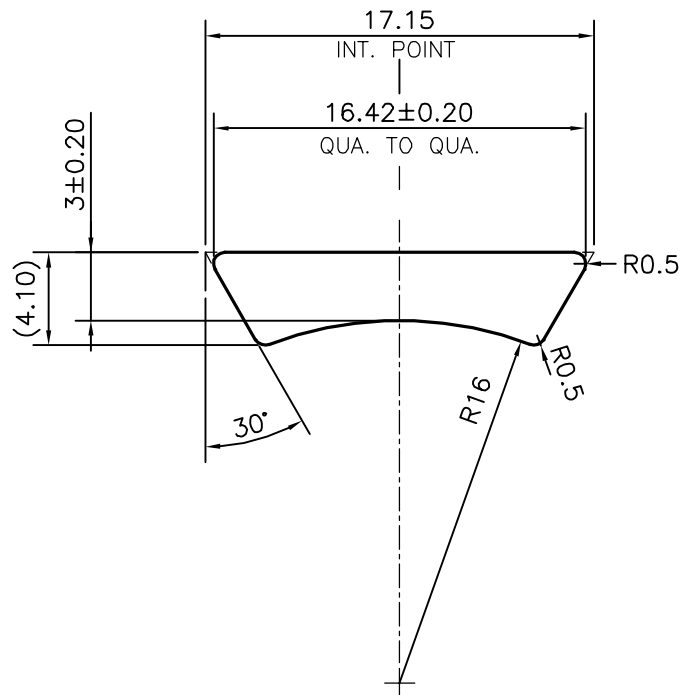

SYMBOL OF QUALITY  
AN ISO 9001 COMPANY

**JINDAL ALUMINIUM LTD.**  
BANGALORE-560073 (INDIA)

	NAME	DATE
DRAWN	J.P.KAUSHIK	22-12-2014
CHECKED		
APPROVED	S.S.GARG	27-12-2014

1. ALL DIMENSIONS ARE IN mm.
2. ROUND OFF ALL SHARP CORNERS WITH 0.50 mm.
3. TOLERANCES WILL BE AS PER IS:3965-1981 , UNLESS OTHERWISE SPECIFIED

SCALE	3:1
AREA mm <sup>2</sup>	51.627
PERIMETER mm.	37.825
WEIGHT kg/m	0.139

PARTY'S NAME	SICAME INDIA CONNECTORS PVT. LTD., KANCHIPURAM
PARTY'S DRAWING No.	AS PER AUTOCAD DRAWING &F10086313 A
ALLOY & TEMPER	6005 T6
DESCRIPTION	INDUSTRIAL SECTION-BEARING PLATE

DRAWING No.	SECTION No.
P-14277	-
S4329	S4329
12296	12296