

2366

13283

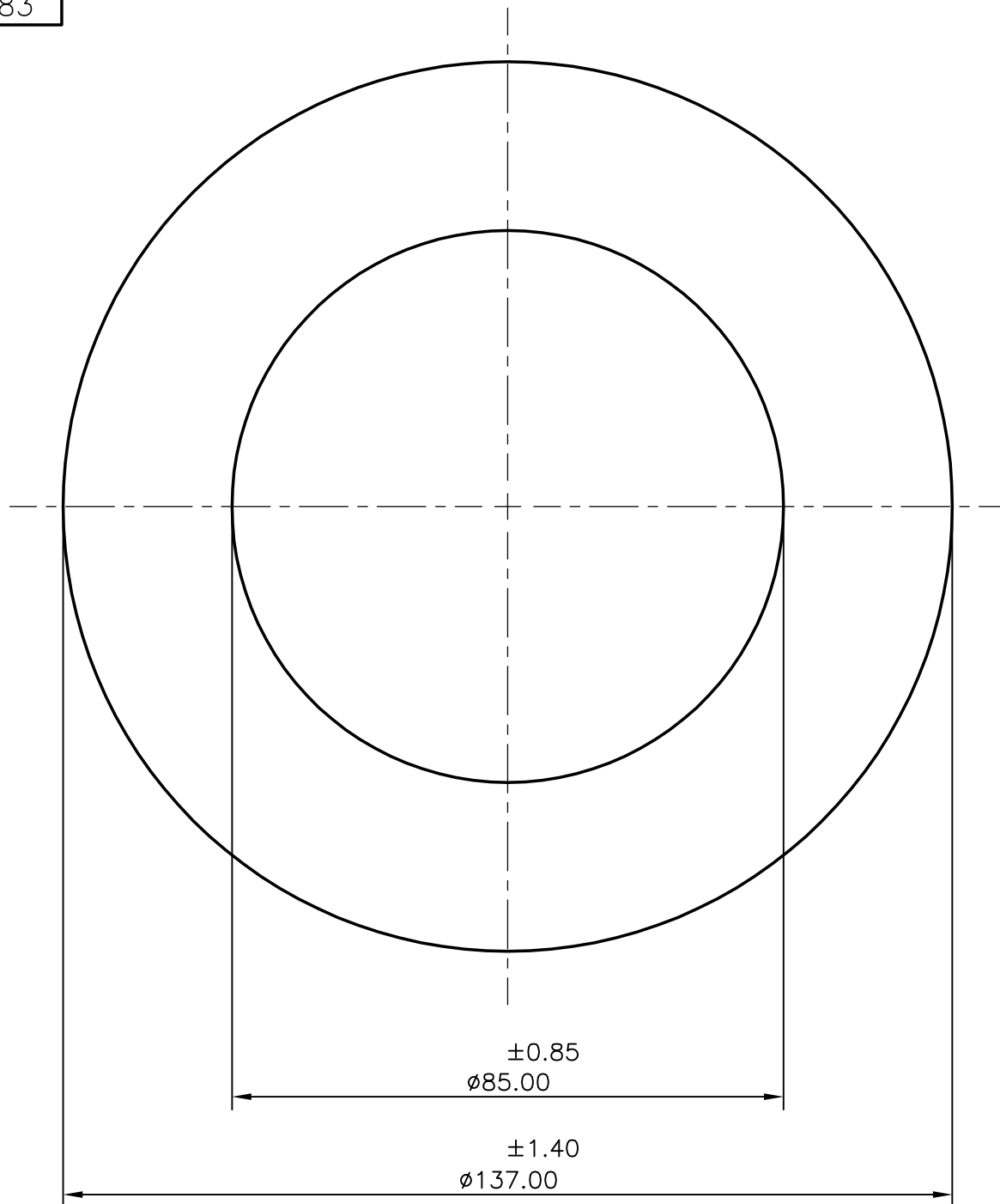

DRAWING No.

S371 ISSUE-2

MAX BEND IS 1,00 mm/mtr

SYMBOL OF QUALITY  
AN ISO 9002 COMPANY

**JINDAL ALUMINIUM LTD.**  
BANGALORE-560073 (INDIA)

	NAME	DATE
DRAWN	P,KULKARNI	13-12-99
CHECKED		
APPROVED		

SCALE	1:1
WEIGHT kg/m	24.480

SECTION No.	13283
-------------	-------

DRAWING No.

13283

1. ALL DIMENSIONS ARE IN mm.
2. ROUND OFF ALL SHARP CORNERS WITH 0.40 mm.
3. TOLERANCES WILL BE AS PER I.S. 2673-1979 UNLESS OTHERWISE SPECIFIED

PARTY'S NAME **BHARAT ELECTRONICS LTD., BANGALORE**PARTY'S DRAWING No. **AS PER SPECIFICATION**ALLOY & TEMPER **6061 T4 (HE20 W)** LENGTH: 1mtr  $\pm 3$ DESCRIPTION **ROUND TUBE**